

BTE SERIES

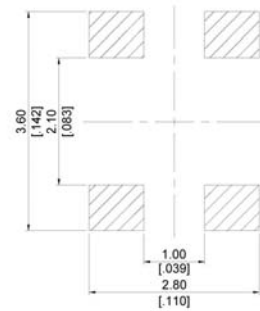

DIMENSIONS

BTE

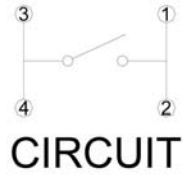
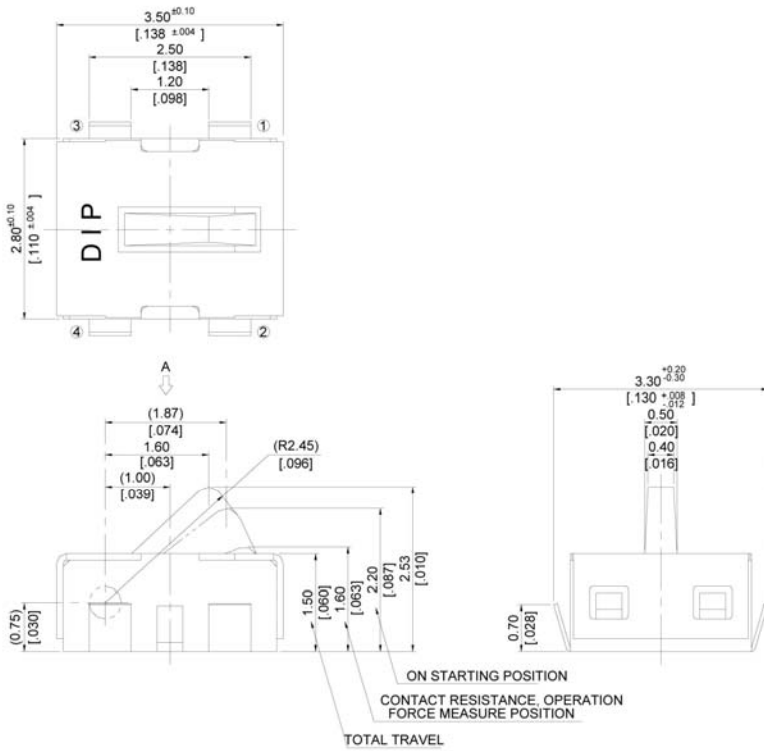

General Tolerance : ±0.2mm

BTE-P

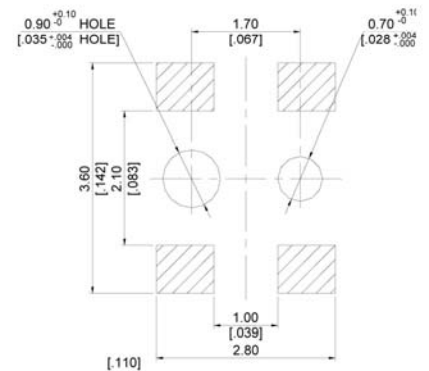
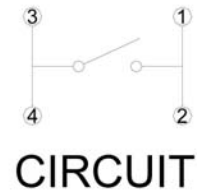
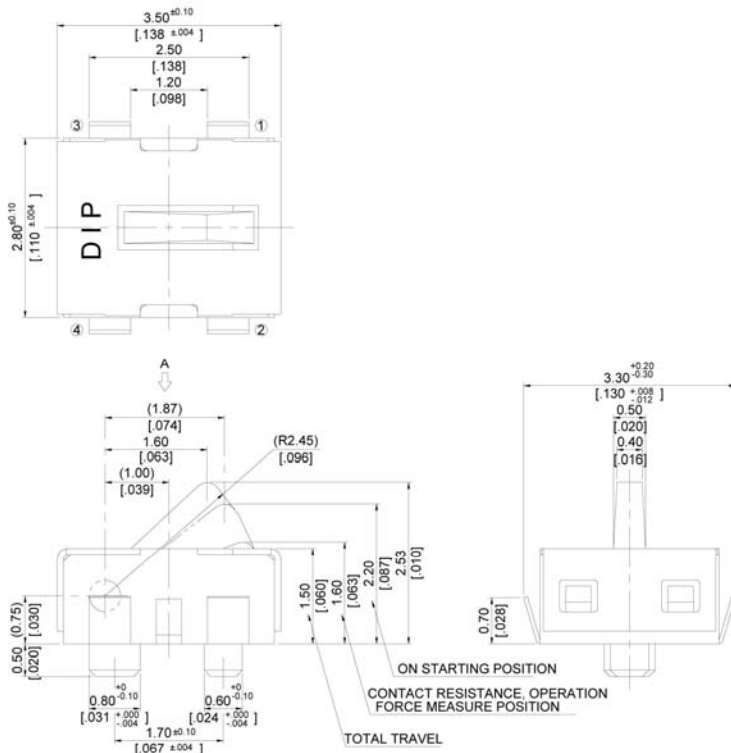

General Tolerance : ±0.2mm

HOW TO ORDER

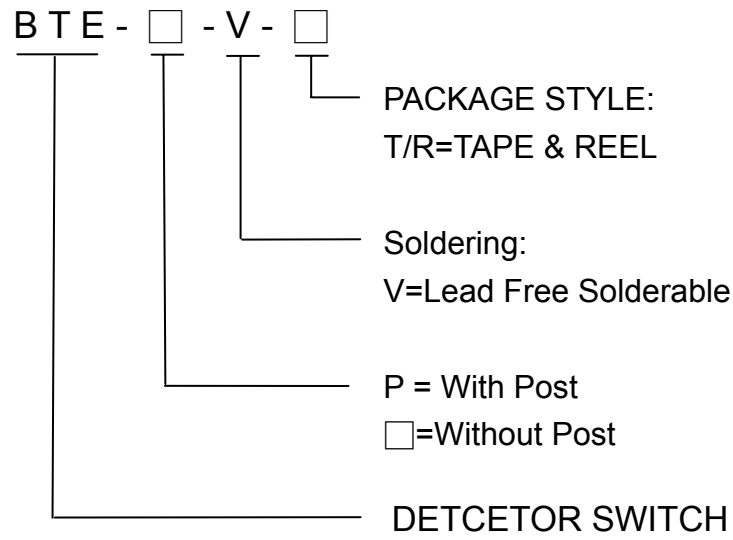

SPECIFICATION

△MECHANICAL

Operation Force : 50gf Max.
Stroke : 1.03mm MAX.
Operation Temperature Range : -10°C to +60°C
Storage Temperature Range : -20°C to +70°C

△ELECTRICAL

Electrical Life : 100,000 cycles
Rating : 1 mA , 5 VDC
Contact Resistance : 2Ω Max.
Insulation Resistance : 100 MΩ Min , at 100 VDC.
Dielectric Strength: 100 VAC / 1 minute.
Contact Arrangement 1 pole 1 throw

MATERIAL

△COVER : Stainless steel.
△CONTACT : Phosphor bronze with silver plated.
△TERMINAL : Phosphor bronze with silver plated.
△BASE : LCP High-Temp. Thermoplastic.
Color : Black
△STEM : LCP High-Temp. Thermoplastic.
Color : Black

SOLDERING PROCESSES

For best results, please follow these recommendation:

△HAND SOLDERING : Use a soldering iron of 30 watts, controlled at 350°C approximately max 5 seconds while applying.

△REFLOW SOLDERING: When applying reflow soldering, the peak temperature or the reflow oven should be set to 260°C max.

△Reflow Temperature Profile:

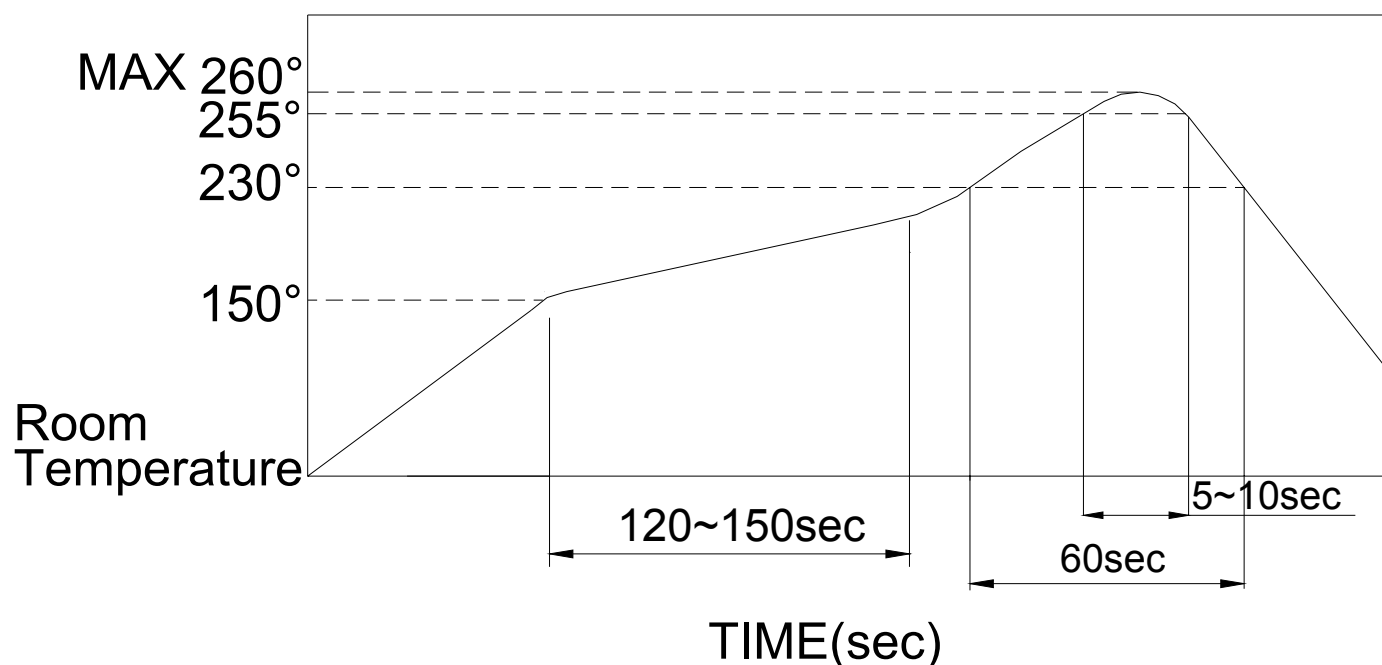

PACKING
REEL

Part Number	Number Per Tube	Number Per Reel
BTE	-	2600
BTE-P	-	

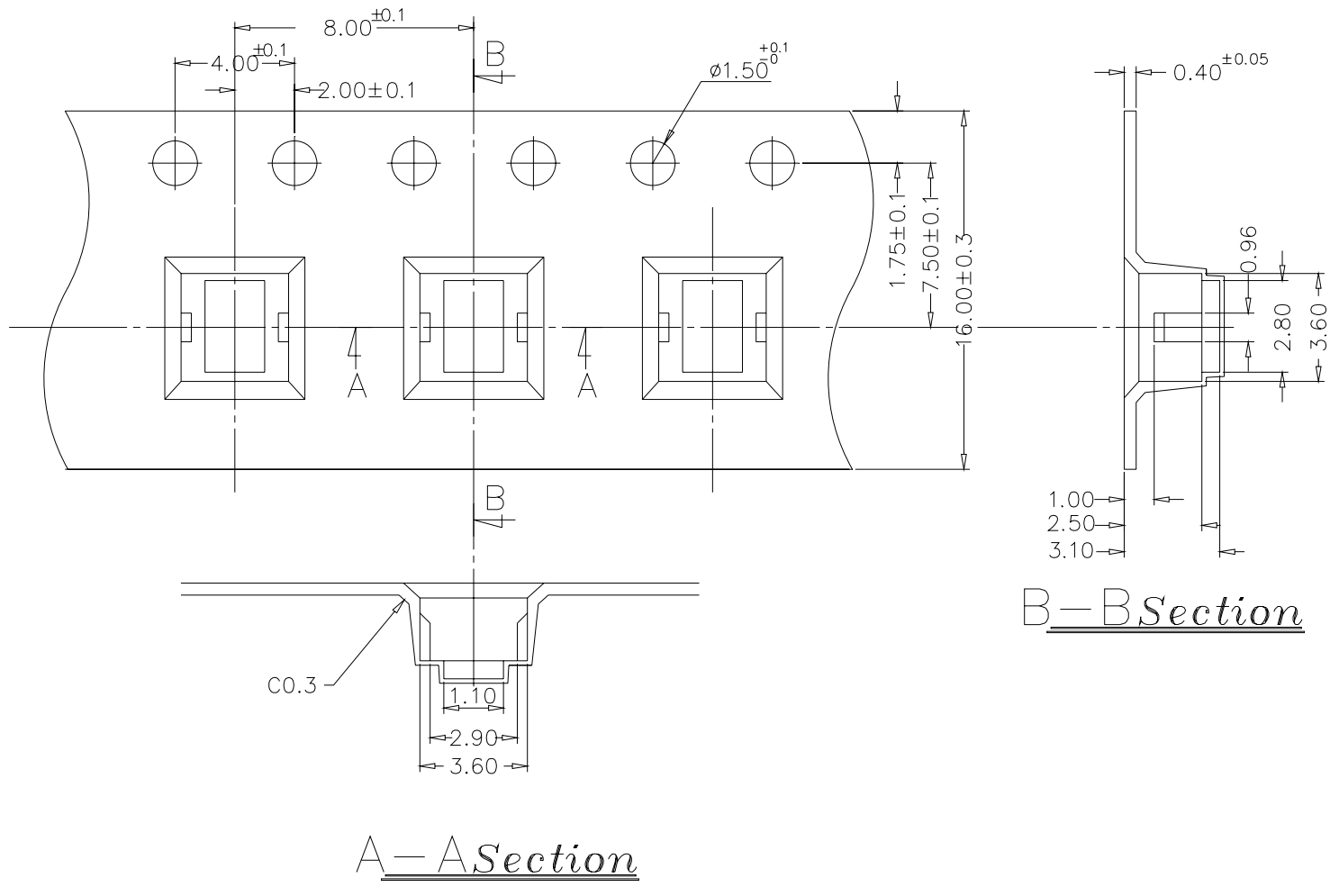

General Tolerance : ± 0.1 mm