

TU SERIES

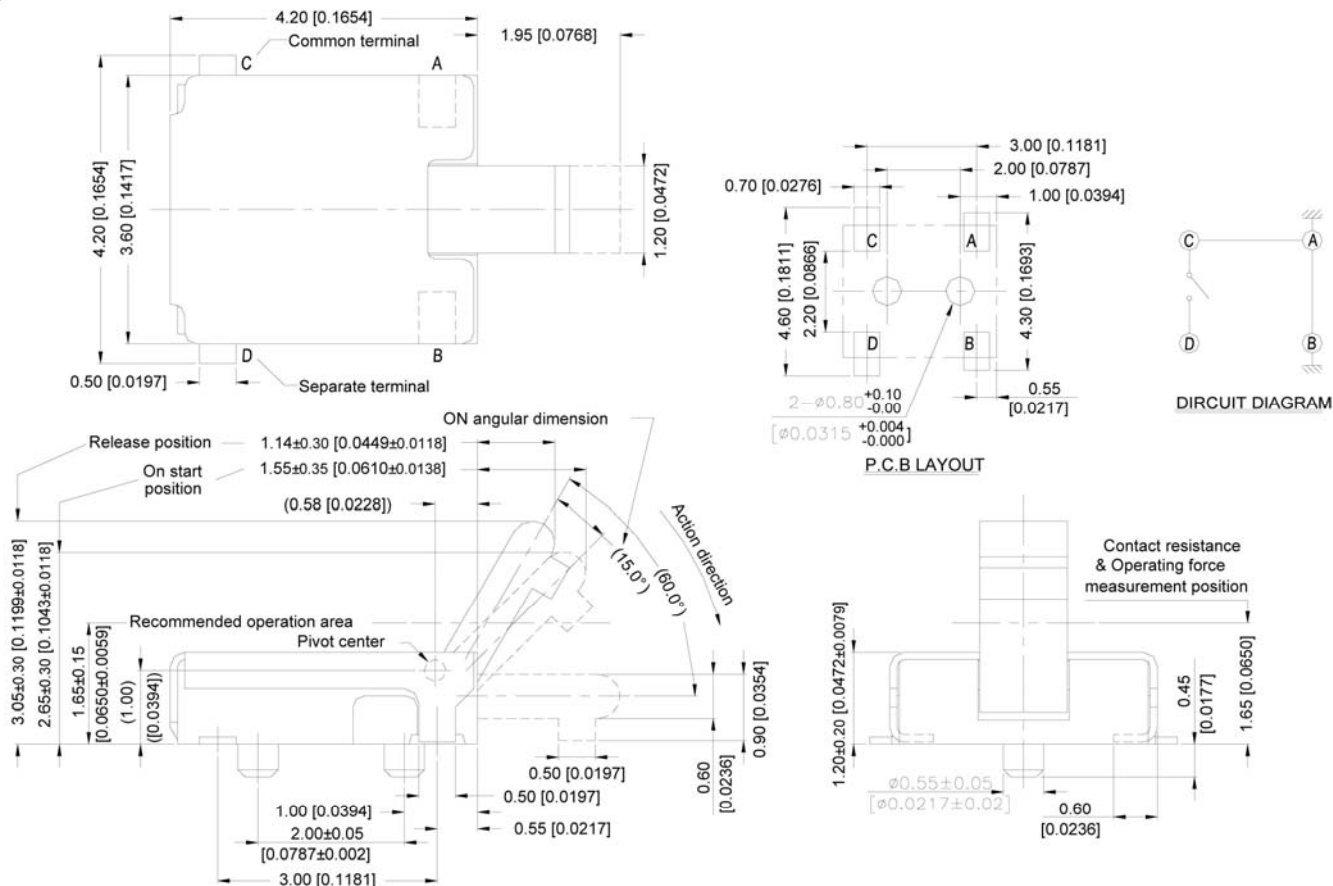

DIMENSIONS

TU-UCF-V



General Tolerance : $\pm 0.2\text{mm}$.

TU-UF-V

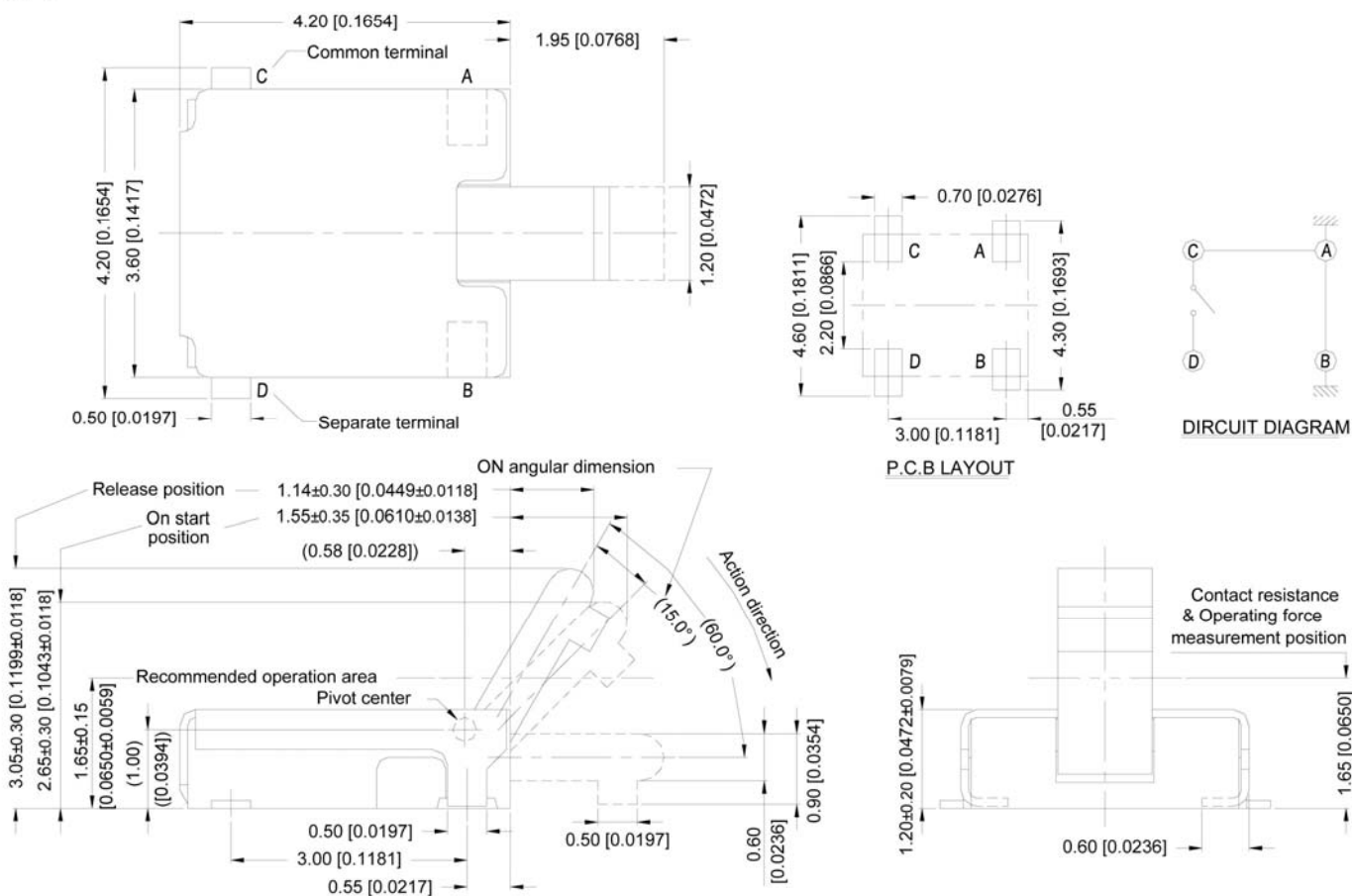

General Tolerance : $\pm 0.2\text{mm}$.

TU-UCL-V

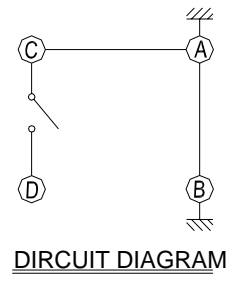
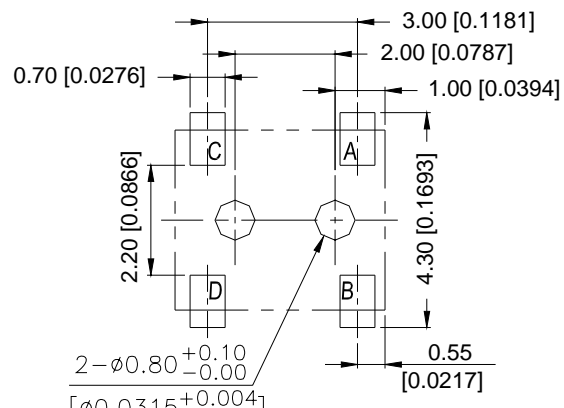
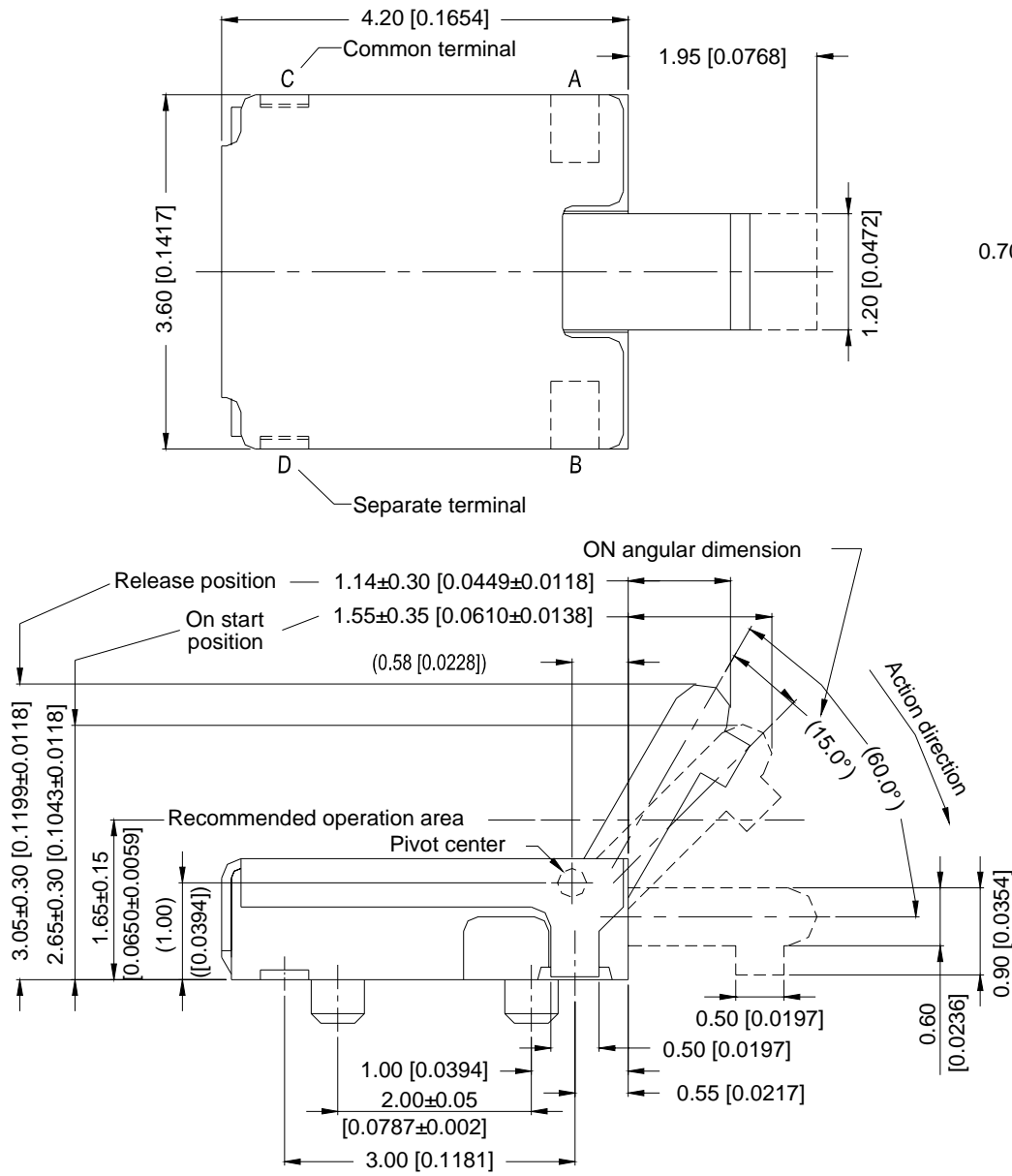

P.C.B LAYOUT

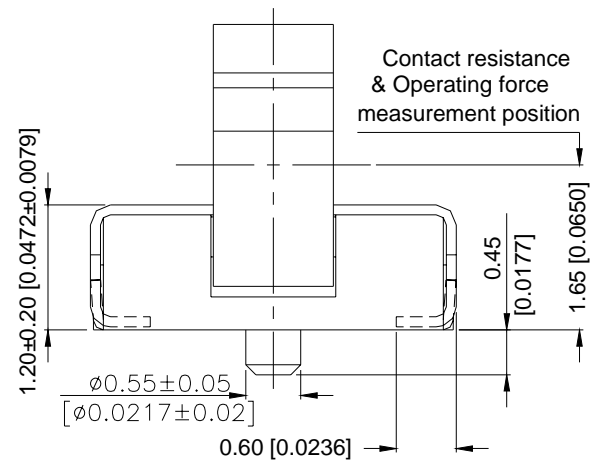

General Tolerance : ±0.2mm.

TU-UL-V

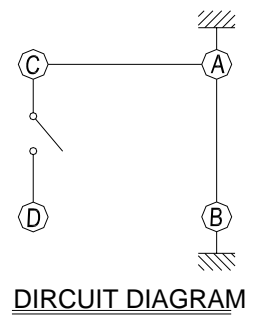
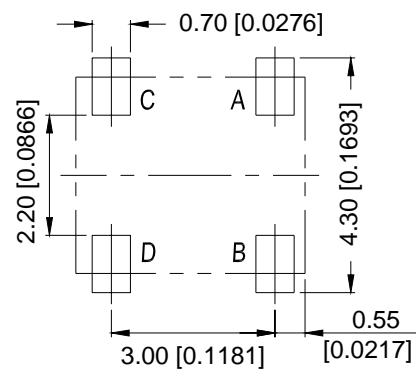
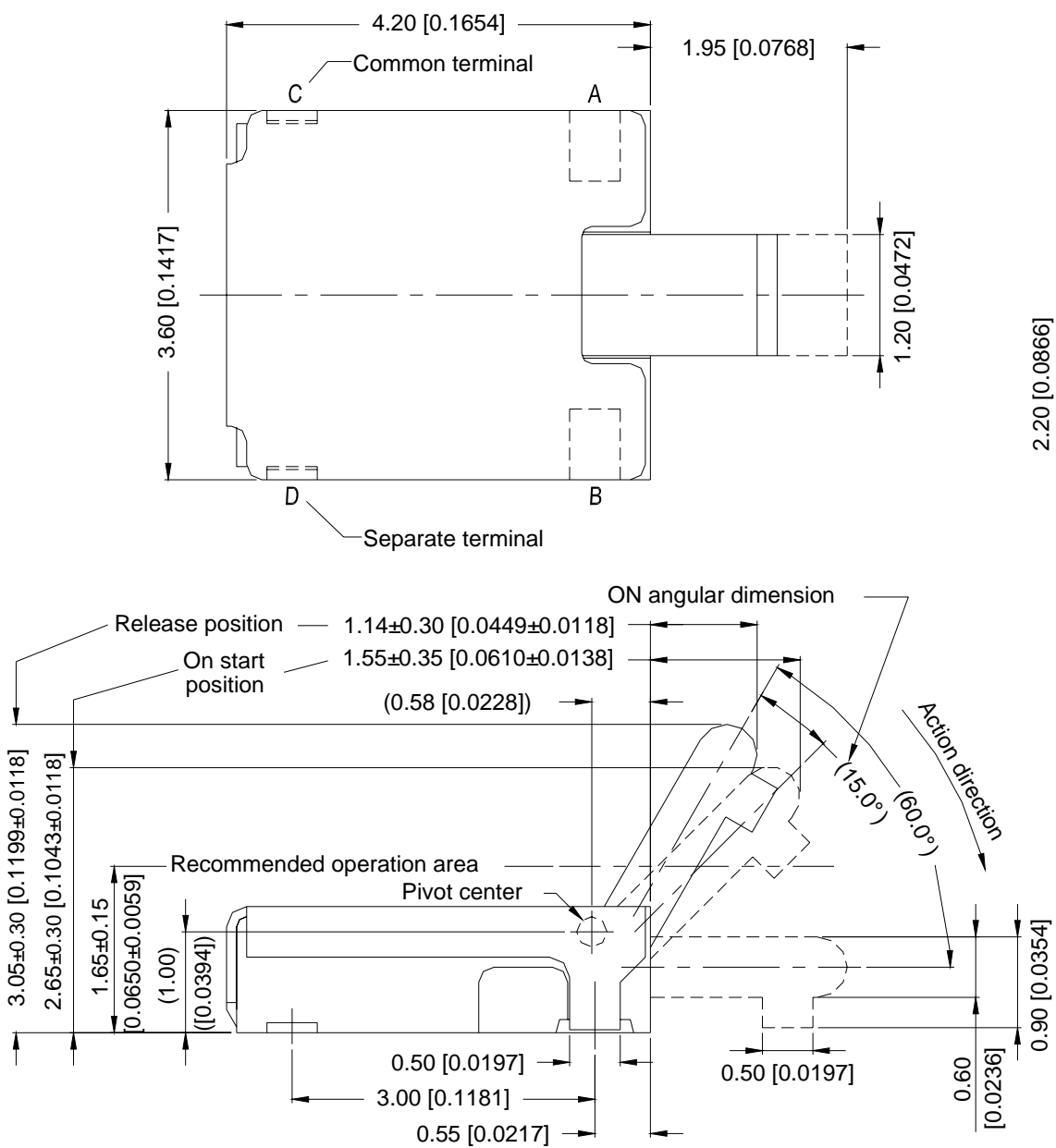

P.C.B LAYOUT

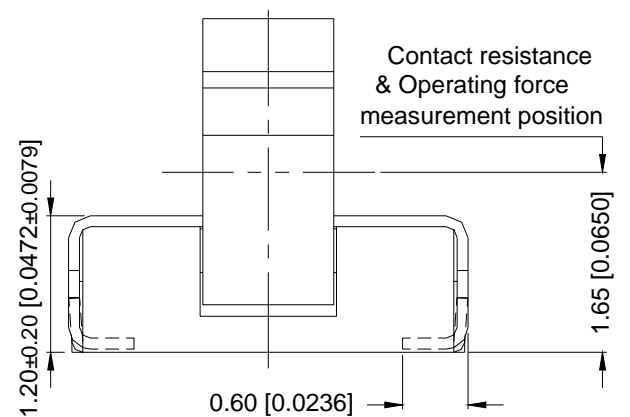

General Tolerance : ±0.2mm.

HOW TO ORDER

T U - U □ □ - V - □

- Package :
T/R = Tape & Reel
- V = Lead Free Solderable
- Terminal Type :
F = Flat
L = Bending
- C = With Post
□ = Without Post
- U = Up lift
- Detector Switch

SPECIFICATION

△MECHANICAL

Mechanical Life: 50,000 operations.
 Operation Force: 40gf max.
 Operation Temperature: -10°C to +60°C
 Storage Temperature: -20°C to +70°C

△ELECTRICAL

Electrical Life: 50,000 cycles.
 Rating: 1 mA 5 V DC.
 Contact Resistance: 1 Ω max.
 Insulation Resistance: 100MΩ min
 Dielectric Strength: 100V AC/1 minute.
 Contact Arrangement: 1pole 1throw

MATERIAL

- △COVER : Nickel Silver
- △STEM(1) : UL94V-0 PA9T High-Temp Thermoplastic.
Color: Black.
- △STEM(2) : UL94V-0 PA9T High-Temp Thermoplastic.
Color: Black.
- △CONTACT : Alloy Copper , gold plated.
- △BASE : UL94V-0 PA9T High-Temp Thermoplastic.
Color: Black.
- △TERMINAL : Brass , gold plated.

SOLDERING PROCESSES

△HAND SOLDERING : Use a soldering iron of 30 watts, controlled at 350°C approximately max 5 seconds while applying.

△REFLOW SOLDERING: When applying reflow soldering, the peak temperature or the reflow Oven should be set at 260°C max.

△Reflow Temperature Profile:

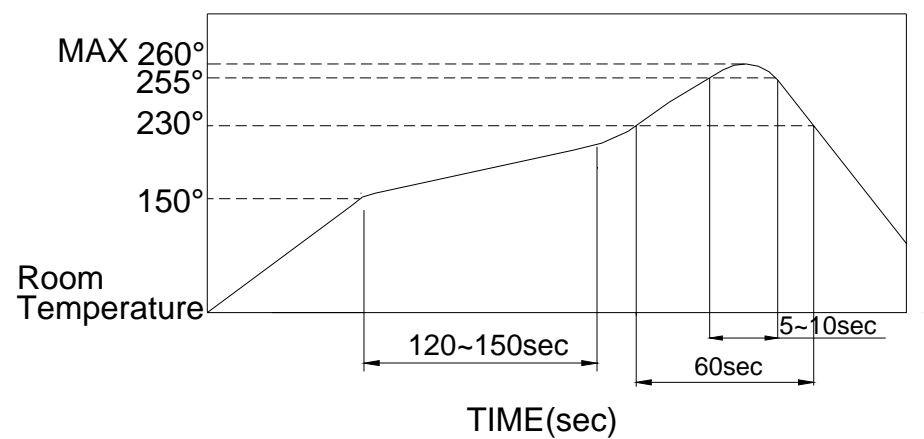

PACKING

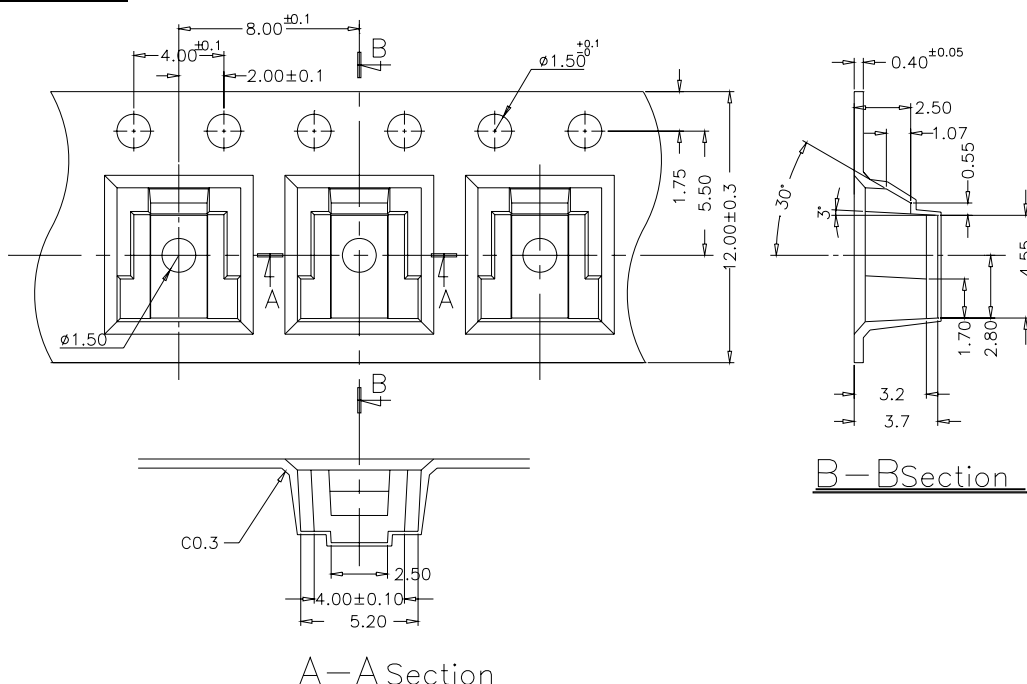

Part Number	Number Per Tube	Number Per Reel
TU-□□□-V	-	2300

General Tolerance : ±0.1mm