

# DTS(M)L-3、DTSMF-3 SERIES

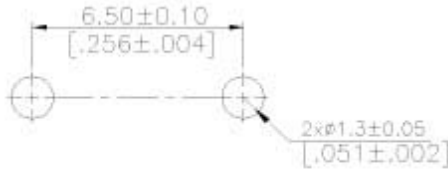

## DIMENSIONS

### DTS-3

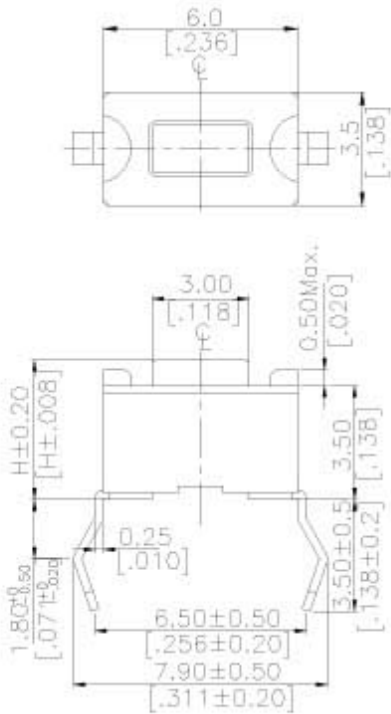

P.C.B. LAYOUT



CIRCUIT DIAGRAM

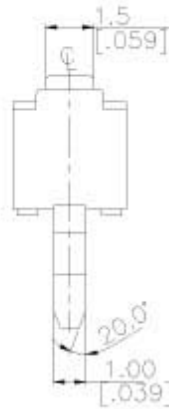

DTS-32□-V	5.0 [0.197]	Y	YELLOW	520g
		S	SALMON	320g
		R	RED	260g
		N	BROWN	160g
DTS-31□-V	4.3 [0.169]	Y	YELLOW	520g
		S	SALMON	320g
		R	RED	260g
		N	BROWN	160g
PROD. NO.	H	COLOR FOR OPERATING FORCE		

General Tolerance : ±0.2mm

### DTSM-3

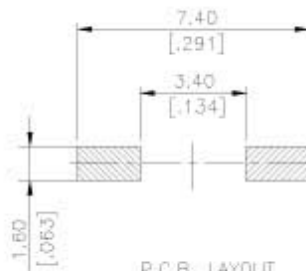
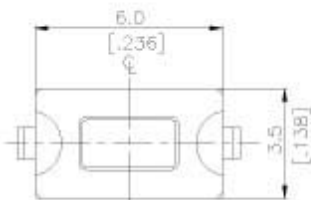

P.C.B. LAYOUT



CIRCUIT DIAGRAM

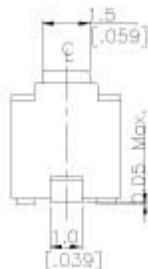
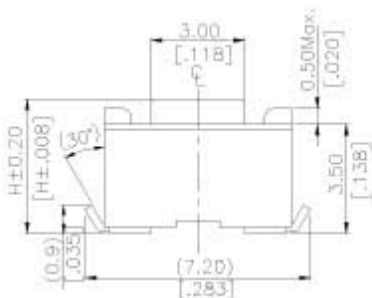

DTSM-32□-V	5.0 [0.197]	Y	YELLOW	520g
		S	SALMON	320g
		R	RED	260g
		N	BROWN	160g
DTSM-31□-V	4.3 [0.169]	Y	YELLOW	520g
		S	SALMON	320g
		R	RED	260g
		N	BROWN	160g
PROD. NO.	H	COLOR FOR OPERATING FORCE		

General Tolerance : ±0.2mm

**DTSML-3**

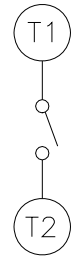
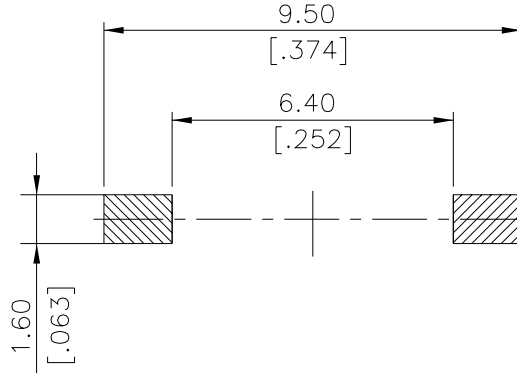
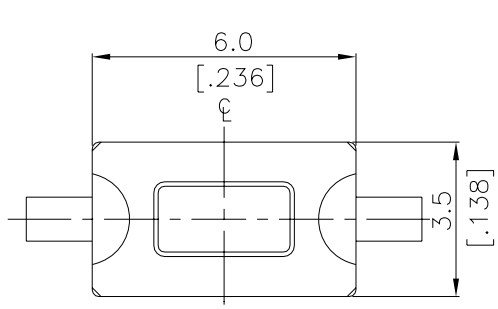

CIRCUIT DIAGRAM

P.C.B. LAYOUT

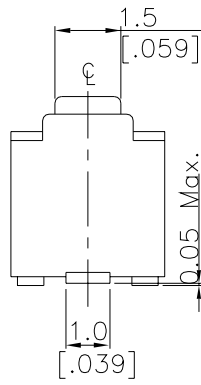
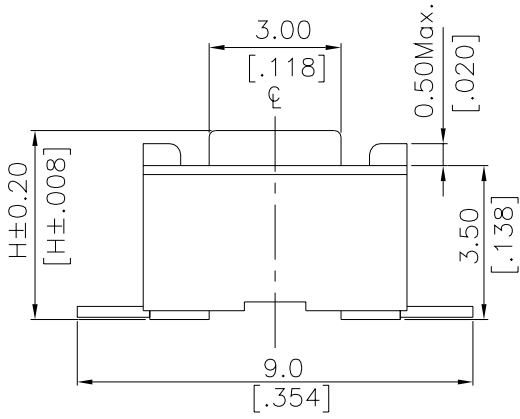

DTSML-32□-V	5.0 [0.197]	Y	YELLOW	520g
		S	SALMON	320g
		R	RED	260g
		N	BROWN	160g
DTSML-31□-V	4.3 [0.169]	Y	YELLOW	520g
		S	SALMON	320g
		R	RED	260g
		N	BROWN	160g
PROD. NO.	H	COLOR FOR OPERATING FORCE		

General Tolerance : ±0.2mm

**DTSMF-3**

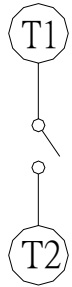
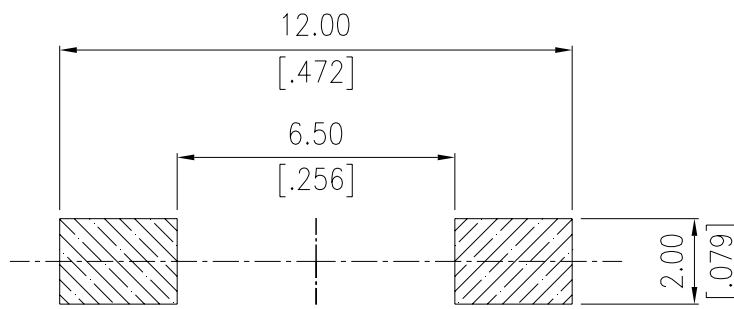
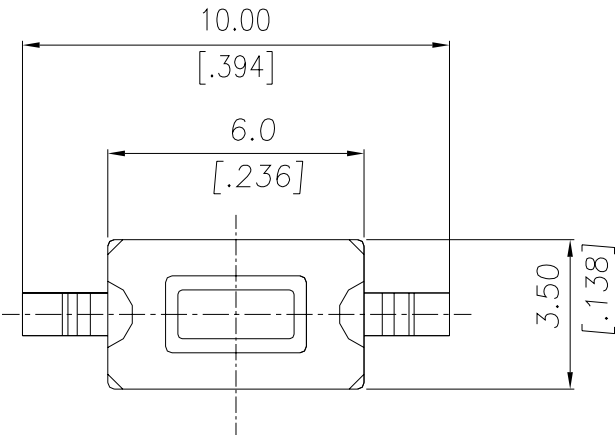

CIRCUIT DIAGRAM

P.C.B. LAYOUT

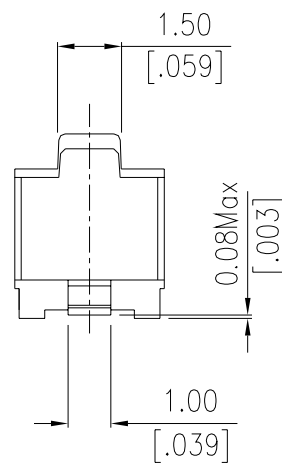
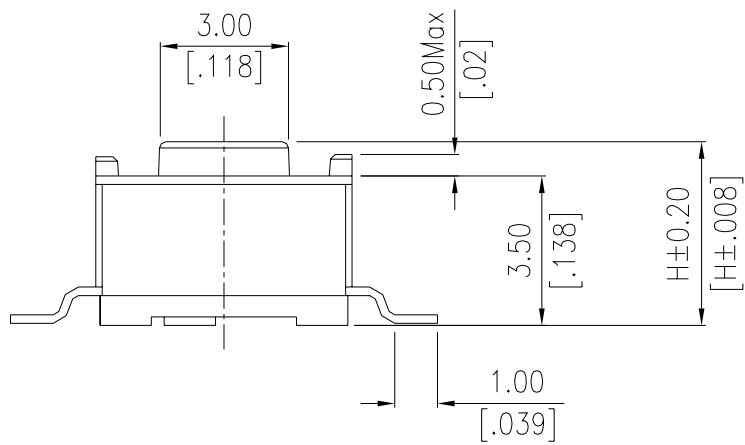

DTSMF-31□-V	4.30	N	BROWN	160g
		R	RED	250g
PARTS NO.	H	COLOR	OPERATING FORCE	

General Tolerance : ±0.2mm

## HOW TO ORDER

DTS- □ - □ □ □ - □ - □

Package Style:  
B = Tube Package  
T/R = Tape & Reel

Soldering:  
V=Lead Free Solderable

Color of Stem for  
Operating Force:  
N = Brown, 160g  
R = Red, 260gf  
S = Salmon, 320gf  
Y = Yellow, 520gf

Dimension H:  
1 = 4.3mm  
2 = 5.0mm

Prod. Size: 3 = 3.5x6mm

M = J Bend Terminal  
□ = Through Hole Type

ML = Flat Terminal

MF = Gull Wing Terminal 「 Only for 260gf、160gf 」

Tactile Switch 3.5x6mm

## SPECIFICATION

### △MECHANICAL

Operation Force: 520 ± 130gf Yellow (Y)  
320 ± 80gf Salmon (S)  
260 ± 50gf Red (R)  
160 ± 50gf Brown (N)

Stroke: 0.25 +0.20 / - 0.1 mm

Operation Temperature: -25°C to +70°C

Storage Temperature: -30°C to +80°C

### △ELECTRICAL

Electrical Life: 50,000 cycles for 160gf, 320gf  
30,000 cycles for 260gf, 520gf

Rating: 50mA, 12VDC

Contact Resistance: 100mΩ max.

Insulation Resistance: 100MΩ min. at 500VDC

Dielectric Strength: 250VAC/ 1minute

Contact Arrangement: 1 pole 1 throw

## MATERIAL

△COVER: Stainless steel

△BASE: UL94V-0 Nylon High-Temp. Thermoplastic

△STEM: UL94V-0 Nylon High-Temp. Thermoplastic  
Color: Brown, (160gf), Red (260gf)  
Salmon (320gf), Yellow (520gf)

△CONTACT DISC: Stainless with silver cladding

△TERMINAL: Brass with silver plated

# SOLDERING PROCESS

△HAND SOLDERING : Use a soldering iron of 30 watts, controlled at 350°C approximately max 5 seconds while applying solder.

△REFLOW SOLDERING: When applying reflow soldering, the peak temperature or the reflow oven should be set at 260°C max.

△WAVE SOLDERING: Recommended solder temperature at 500°F (260°C) max. 5 seconds for through hole type. subject to P.C.B 1.6mm thickness.

△Reflow Temperature Profile:

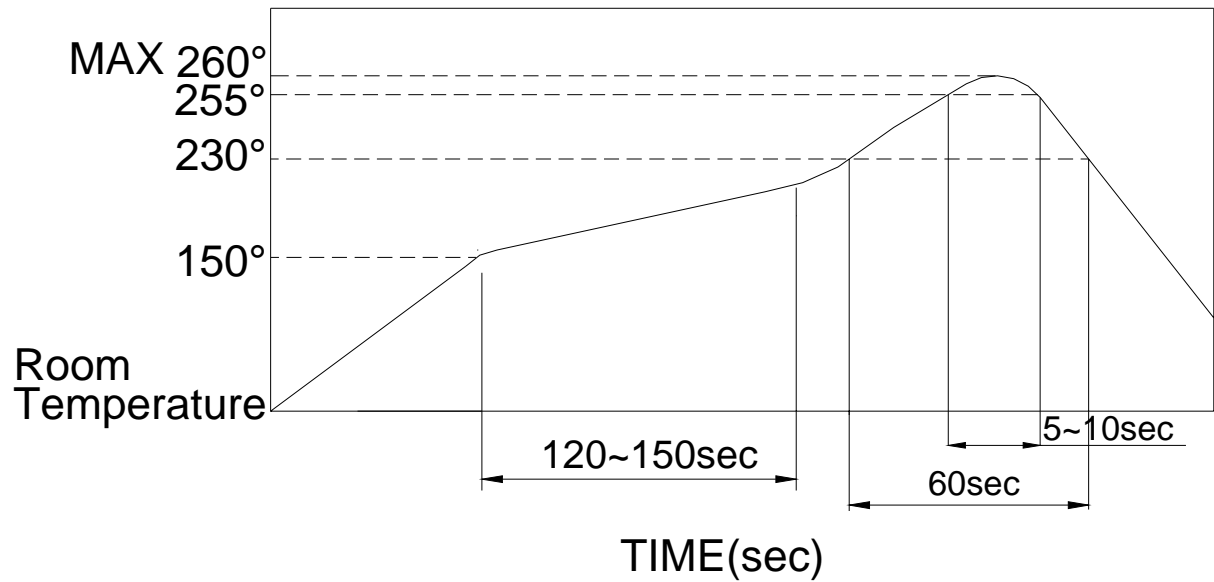

## PACKING

Part Number	Number Per Tube	Number Per Reel
DTS-3	135	-
DTS(M)L-31	135	1800
DTS(M)L-32	135	1600

## TUBE

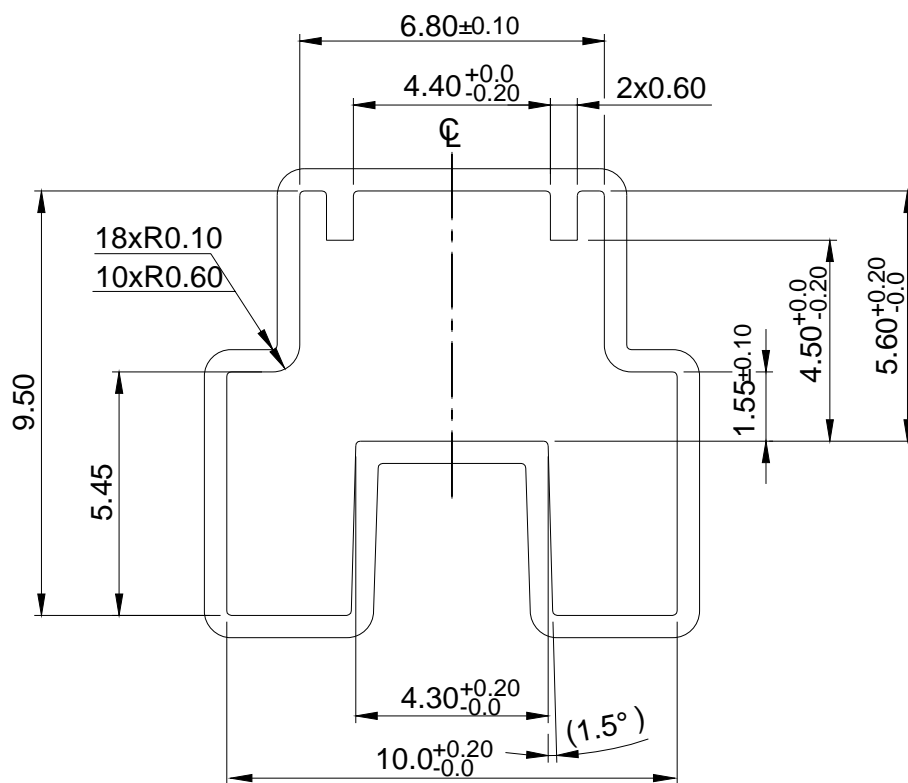

General Tolerance : ±0.2mm

**REEL**

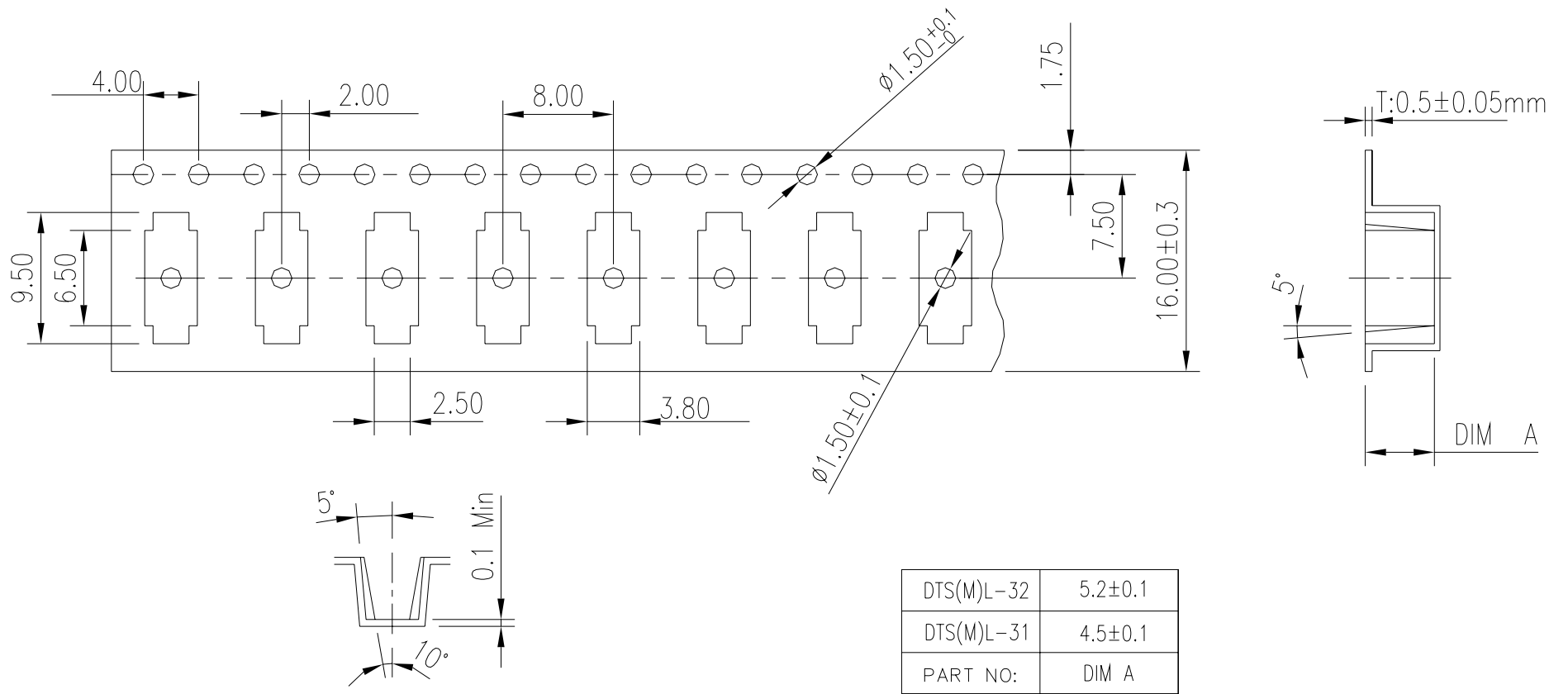

General Tolerance :  $\pm 0.1 \text{ mm}$