

MT5-L

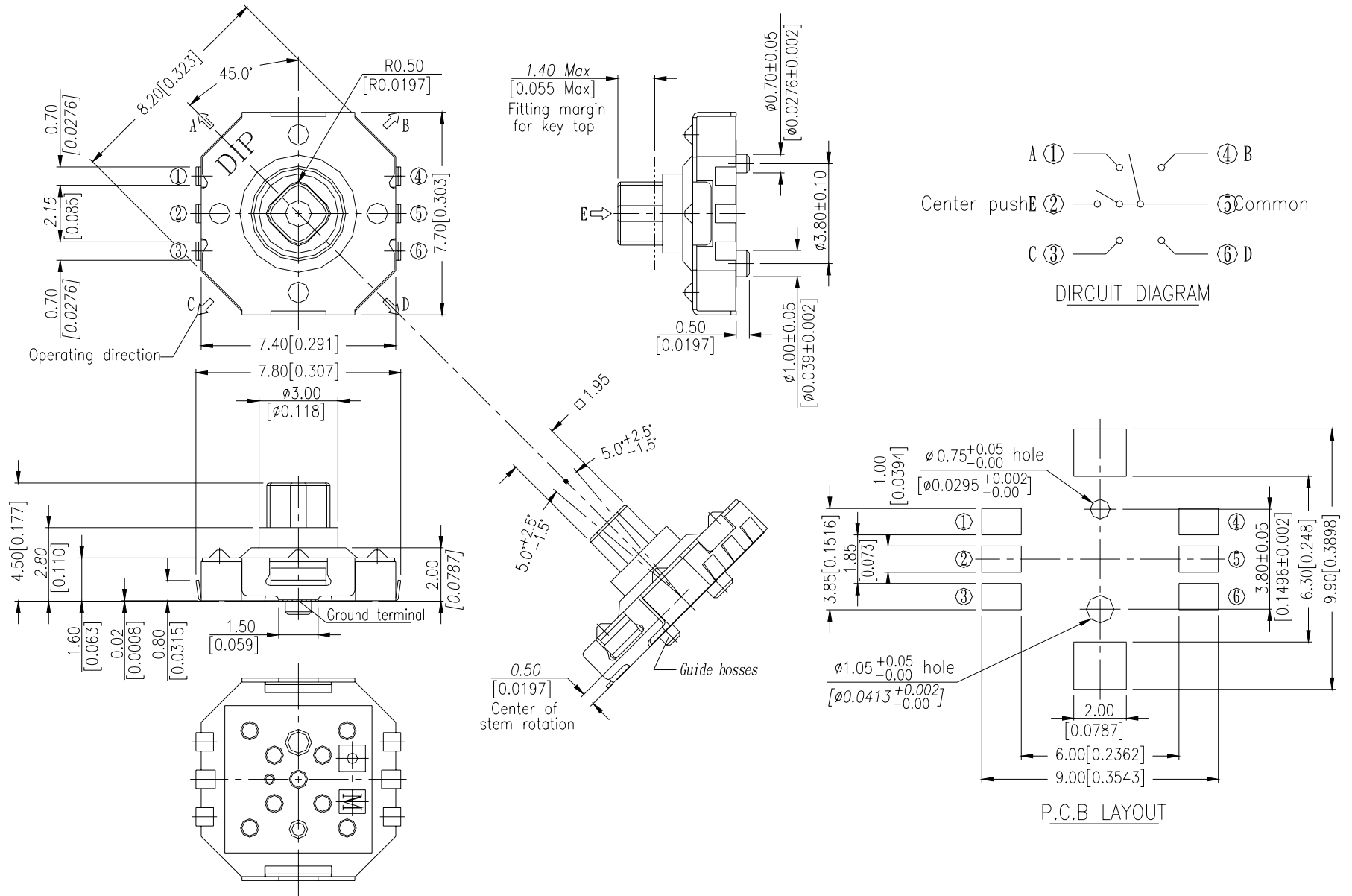

General Tolerance : $\pm 0.2\text{mm}$

HOW TO ORDER

MT - - - -

Package :
T/R = Tape & Reel

Soldering :
V = Lead Free Solderable

L = With J Bend Terminal
F = With Flat Terminal

= 4.5 mm
1 = 5.0 mm (Only 5 Directions)
2 = 4.0 mm (Only 5 Directions)

5 = 5 Directions
4 = 4 Directions

SPECIFICATION

△MECHANICAL

Operation Force: 4-direction: 160gf
 Center push: 320gf
 Stroke: 4- direction: 5°+2.5°/-1.5° mm
 Center push: 0.25+0.1/-0.2 mm
 Operation Temperature Range: -25°C to +85°

△ELECTRICAL

Electrical Life: 100,000 cycles
 Rating: 50mA, 12VDC
 Contact Resistance: 100mΩ max.
 Insulation Resistance: 100MΩ min. at 100VDC
 Dielectric Strength: 250VAC/1 minute
 Contact Arrangement: 1 pole 1 throw

MATERIAL

△BASE: UL94V-0 Nylon High-Temp. Thermoplastic
 Color: Black
 △COVER : Nickel silver
 △CENTER STEM: Nylon High-Temp Thermoplastic
 5Directions Color: Black
 4Directions Color: Brown
 △FOUR WAY STEM: Nylon High-Temp Thermoplastic
 △CONTACT : Stainless with silver cladding
 △TERMINAL: Brass with silver plated

SOLDERING PROCESSES

△Hand Soldering : Use a soldering iron of 30 watts,
 controlled at 350°C approximately
 5 seconds while applying

△Reflow soldering : When applying reflow soldering, the
 peak temperature or the reflow over
 should be set to 260°C max

△Temperature Profile:

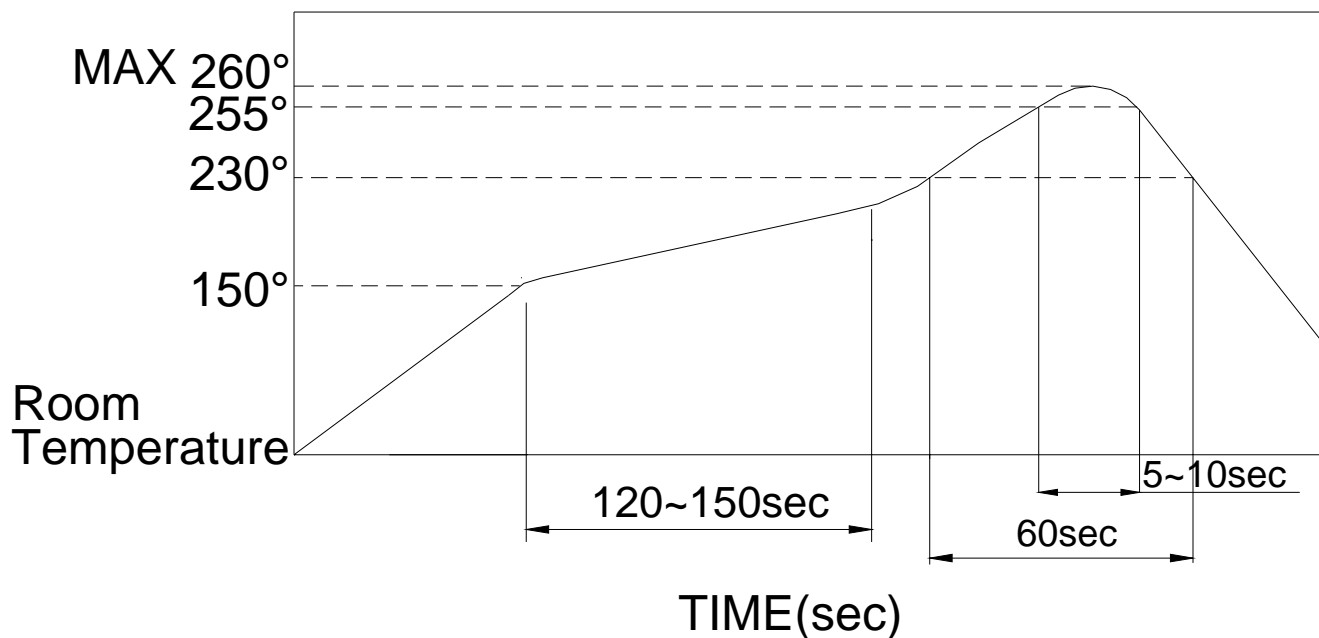

PACKING

Part Number	Number Per Tube	Number Per Reel
MT4	-	850
MT5	-	850

MT5 REEL

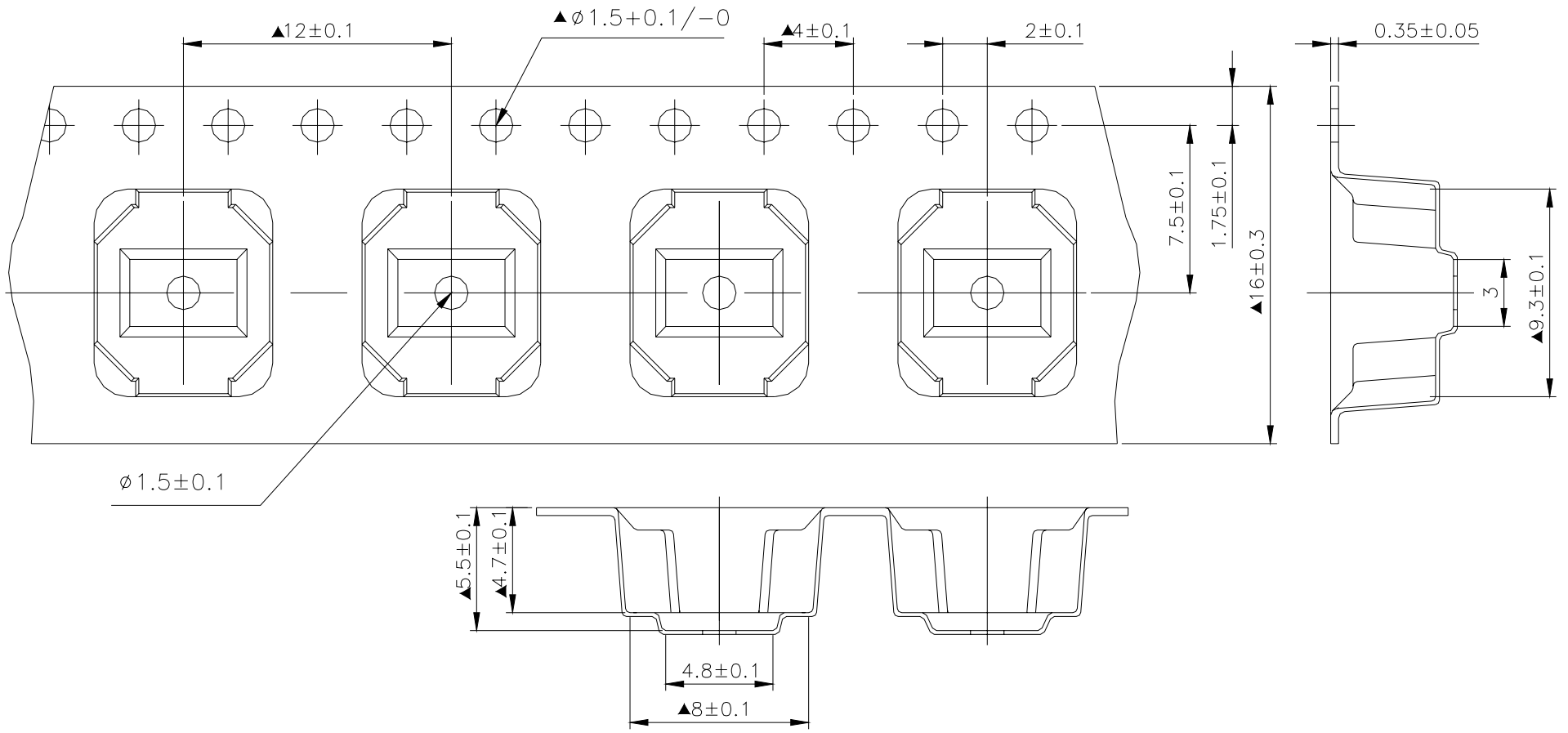

General Tolerance : ± 0.1 mm

MT4 REEL

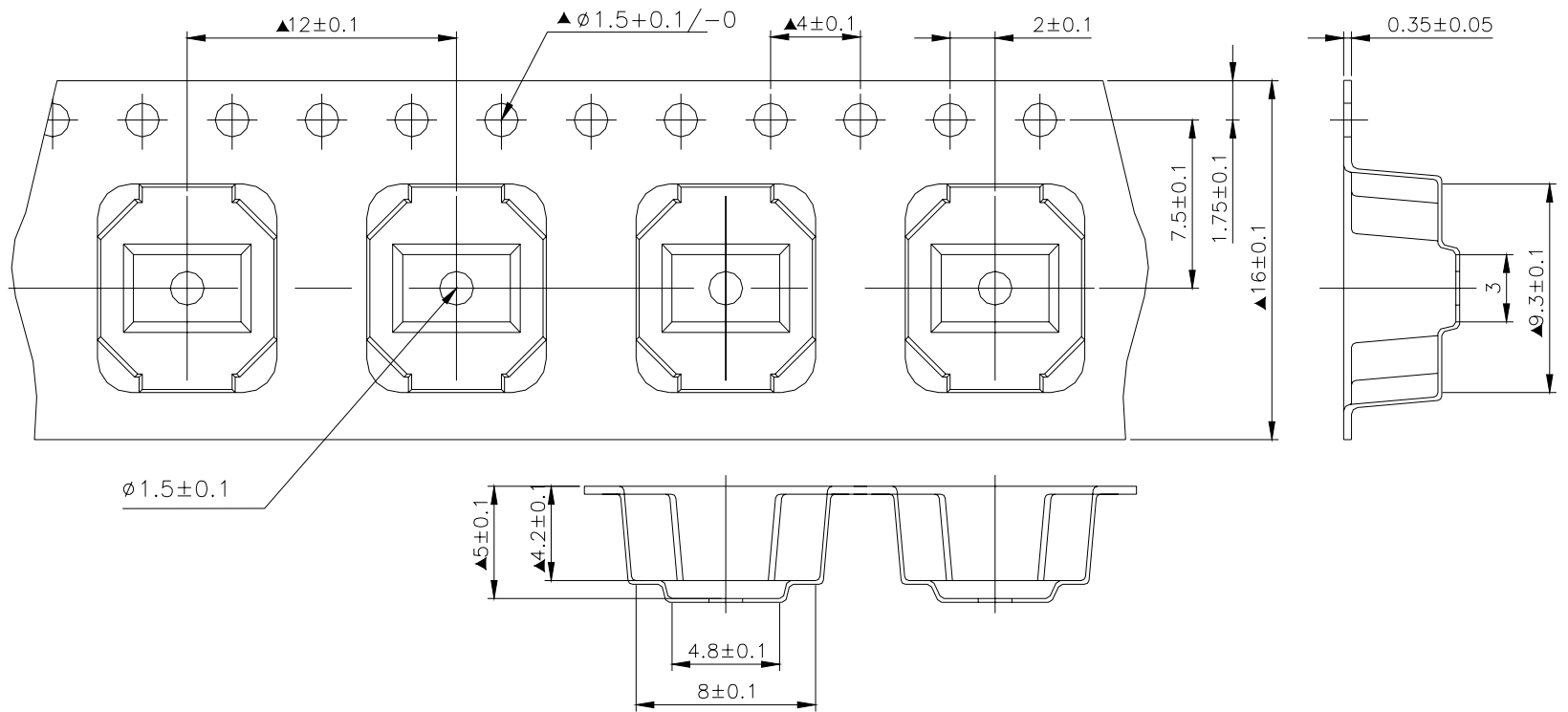

General Tolerance : ± 0.1 mm