

FEATURES

- ✧ Guiding post offers easy orientation
- ✧ Operation force: 35gf max.

APPLICATION

- ✧ Open/close detection
- ✧ Notebook
- ✧ DSC

SPECIFICATION

Contact Rating	0.1mA~100mA, 20mV~5V DC
Contact Resistance	500mΩ max.
Insulation Resistance	100MΩ min. 250V DC
Dielectric Strength	250V AC/1 minute
Operating Force	35gf max.
Travel	1.05mm
Operating Life	80,000 cycles
Operating Temp.	-15°C ~ +70°C
Storage Temp.	-40°C ~ +85°C

CIRCUIT

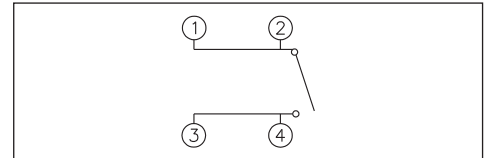

PACKAGE

<Tape & Reel>
1800 pcs

HOW TO ORDER

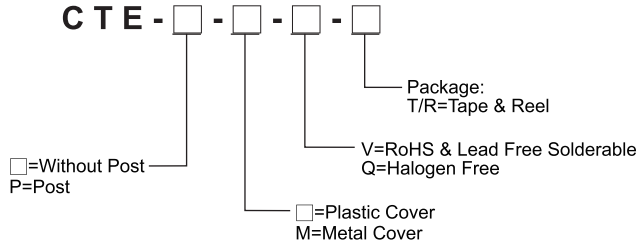

CTE-M

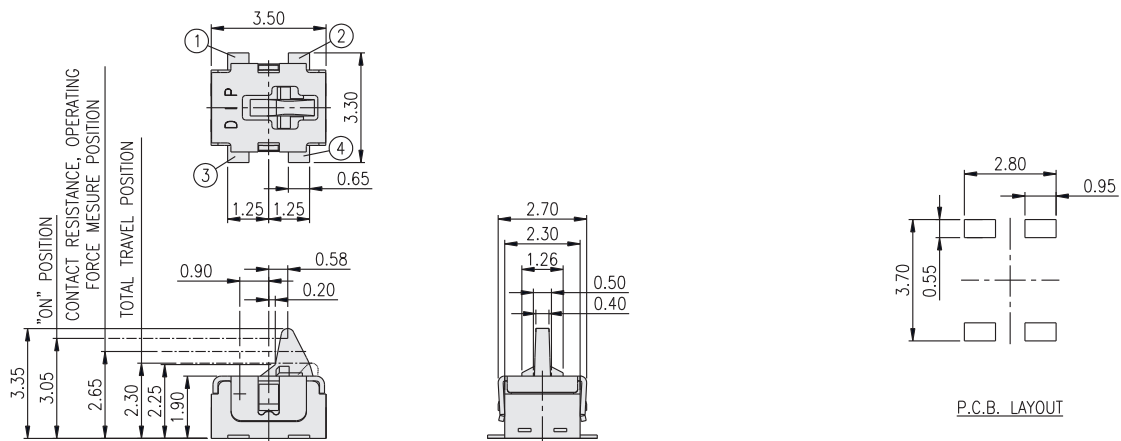

CTE-P

