

FEATURES

- ✘ Ultra-thin with height 1.2 mm
- ✘ Flat & bending terminal available

APPLICATION

- ✘ Detection of video cameras
- ✘ Mobile Phone

SPECIFICATION

| | |
|-----------------------|----------------------------|
| Contact Rating | 50uA, 3V DC to 10mA, 5V DC |
| Contact Resistance | 1Ω max. |
| Insulation Resistance | 100MΩ min. |
| Dielectric Strength | 100V AC/1 minute |
| Operating Force | 40gf max. |
| Travel | 60° |
| Operating Life | 50,000 cycles |
| Operating Temp. | -10°C ~ +60°C |
| Storage Temp. | -20°C ~ +70°C |

CIRCUIT

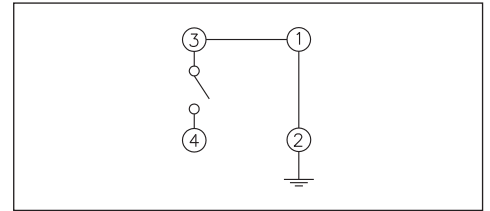

PACKAGE

<Tape & Reel>
2300 pcs

HOW TO ORDER

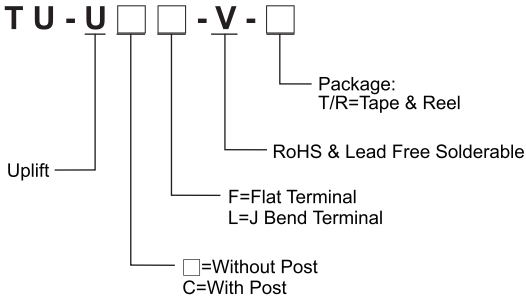

TU-UL

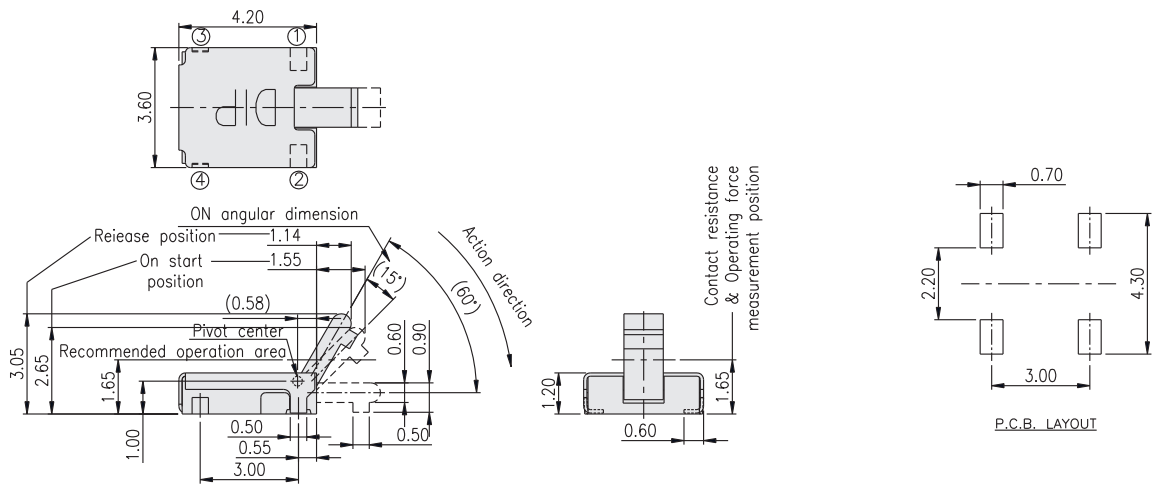

TU-UCF

