



1H Series

High Current Sealed Toggle Switch

IP 67
ACCORDING TO
EN 60529:1989+A1:2001
IEC 60529:2001

C_{UL} US
E 187490

RoHS
compliant

Pb
lead-free

1H
Toggle Switches



SPECIFICATIONS

CONTACT RATING: 12 Amps @125/250 VAC.

MECHANICAL LIFE: 30,000 make-and-break cycles.

CONTACT RESISTANCE: 20 mΩ max. (initial value) @ 2-4VDC
100mA for both silver and gold plated contacts.

INSULATION RESISTANCE: 1,000 MΩ min./500VDC

DIELECTRIC STRENGTH: 1,500 Vrms min.@sea level.(initial value)

OPERATING TEMPERATURE: -30°C to 85°C.

MATERIALS

CASE: Diallyl phthalate (NYLON) (UL94v-0)

ACTUATOR: Brass, chrome plated.

BUSHING: Zin+Silicon.

CONTACT: Copper, Silver plated.

TERMINAL: Copper, Nickel plated.

HOW TO ORDER

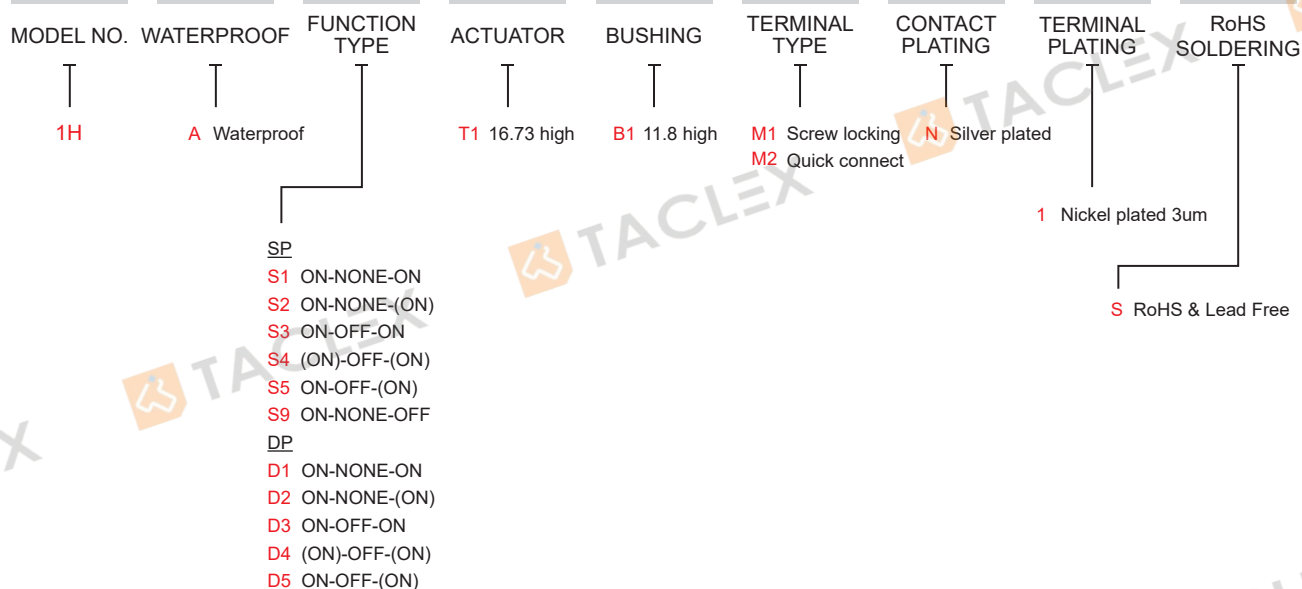

EXAMPLE: 1HAS1T1B1M1N1S



▼ SWITCH FUNCTION

NO. POLES	TYPE	SWITCH FUNCTION			CONNECTED TERMINALS / SCHEMATIC		
		POS.1	POS.2	POS.3	POS.1	POS.2	POS.3
SP	S1	ON	NONE	ON		N/A	2-1
	S2	ON	NONE	(ON)	2-3		
	S3	ON	OFF	ON		OPEN	
	S4	(ON)	OFF	(ON)			
	S5	ON	OFF	(ON)		N/A	OPEN
	S9	ON	NONE	OFF			
DP	D1	ON	NONE	ON	2-3, 5-6	N/A	2-1, 5-4
	D2	ON	NONE	(ON)			
	D3	ON	OFF	ON		OPEN	
	D4	(ON)	OFF	(ON)			
	D5	ON	OFF	(ON)			

()=MOMENTARY

▼ POLE OPTIONS

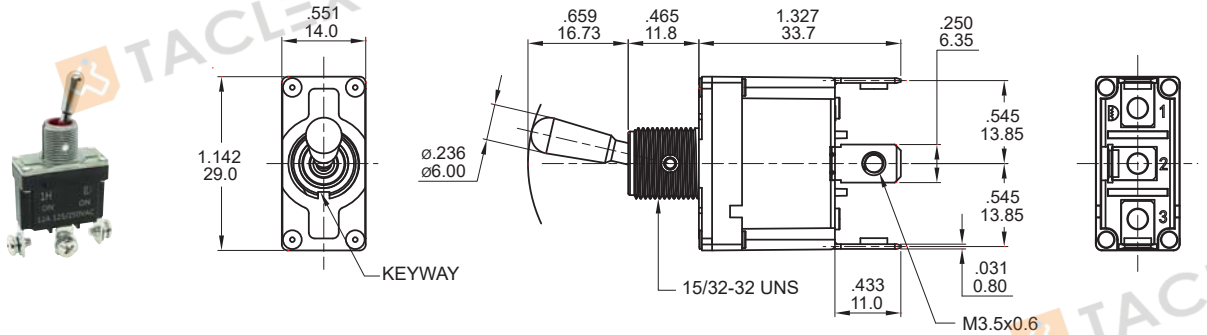

SPDT

Model name. 1HAS1T1B1M1N1S

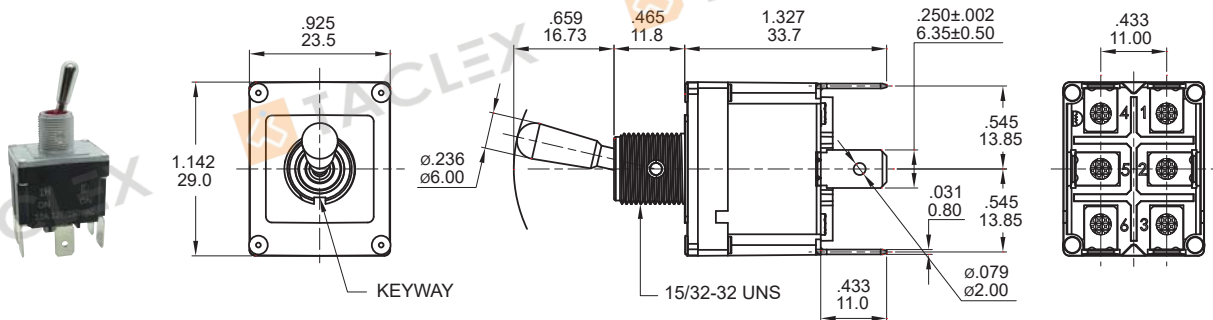

DPDT

Model name. 1HAD1T1B1M2N1S



▼ ACTUATOR & BUSHING OPTIONS

T1 STD

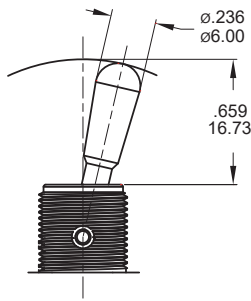

B1 STD

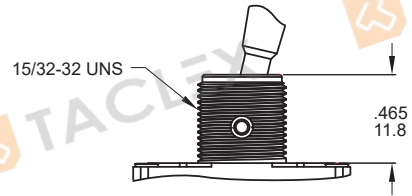

▼ TERMINAL OPTIONS & PANEL MOUNTING

M1 Screw locking

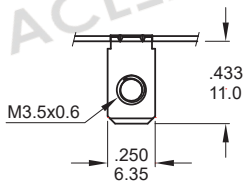

.031inch(0.80mm) THK.

M2 Quick connect

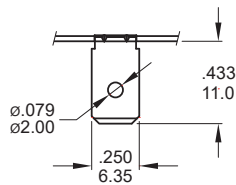

.031inch(0.80mm) THK.

15/32 IN BUSHING

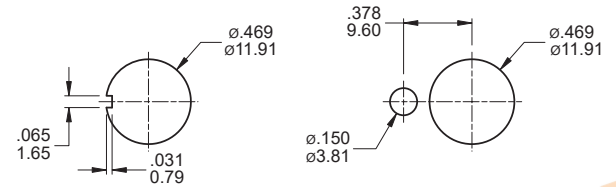

Without locking ring (Keyway)

With standard locking ring.

▼ HARDWARE

EXAMPLE: Model name.

5 Standard hardware

* Standard : 2 nut, 1 locking ring, 1 lockwasher
* For further information please consult sales representative.

15/32 NUT (Std.)

Model name. MNU1M07

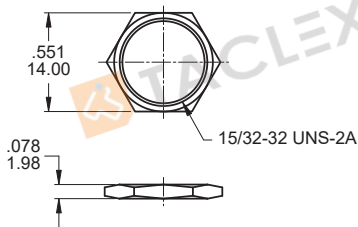

LOCKING RING (Std.)

Model name. NV-MNU-1M08-ZB

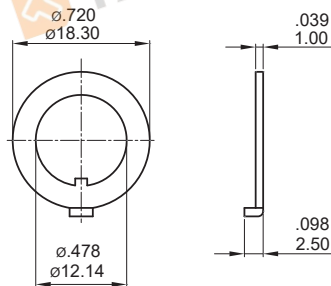

LOCKWASHER (Std.)

Model name. MNU-1M74

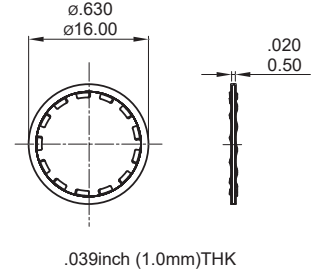

M3.5 SCREW (Std.)

Model name. MNU-1H02

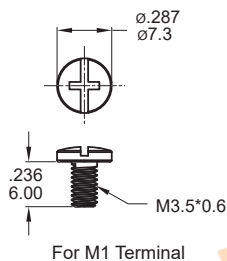

WASHER (Std.)

Model name. MNU-1H01

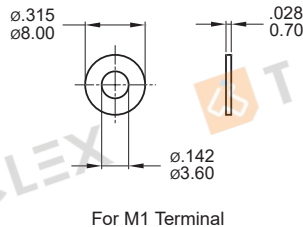

SPRING WASHER (Std.)

Model name. MNU-1H05

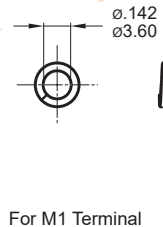

▼ SOLDERING PROCESS

MANUAL SOLDERING: Use 30 watts soldering iron and controlled the temperature at 350°.

Duration of solder immersion: Max. 5 sec.

WAVE SOLDERING: Recommend soldering temperature: 260 ± 5°C

Duration of solder immersion: Max. 5 sec. (PCB thickness is 1.6mm)