

QC DRAWING

REV.	DESCRIPTION	APPVL. BY	DATE	ECN NO.
A	RELEASE	Emily Suen	31/12/10*	
B				
C				

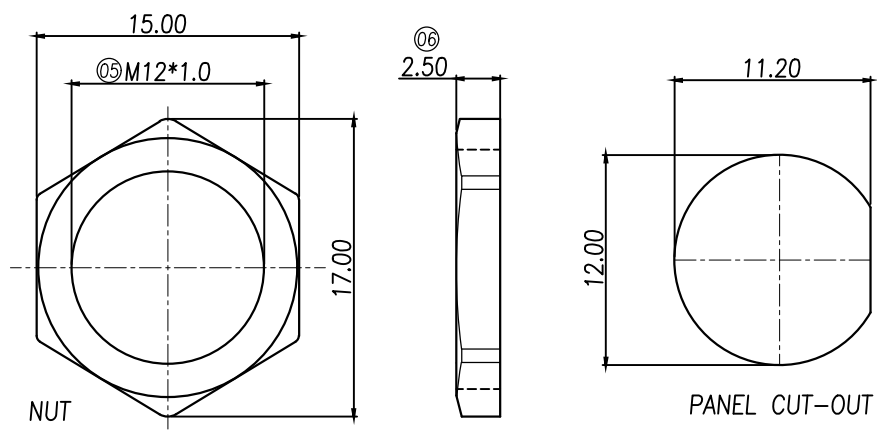
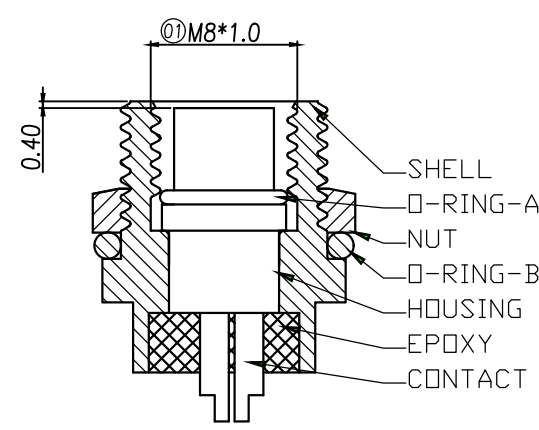
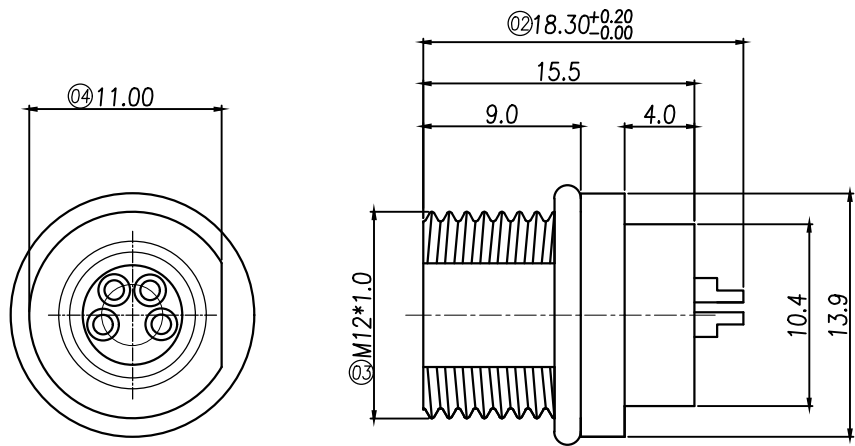

TABLE A

TWP-S04F2-74	STAINLESS STEEL
TWP-S04F2-61	BRASS
P/N	NUT & SHELL MATERIAL

1. MATERIAL :
 - 1-1. HOUSING : PBT UL94V-0 ; COLOR : BLACK
 - 1-2. CONTACT : BRASS
 - 1-3. NUT : SEE TABLE A
 - 1-4. SHELL : SEE TABLE A
 - 1-5. O-RING-A : NBR ; COLOR : BLACK
 - 1-6. O-RING-B : EPDM ; COLOR : BLACK
2. FINISH :
 - 2-1. CONTACT : 10 MICRO INCHES MIN. GOLD PLATED
UNDER PLATE : NICKEL
 - 2-2. NUT : NICKEL PLATED
 - 2-3. SHELL : NICKEL PLATED
3. ELECTRICAL SPECIFICATION :
 - 3-1. Rated current : 5A
 - 3-2. Rated Voltage : 125V
 - 3-3. Water proof : IPX7
4. Environmental :
 - 4-1. Operation Temperature : -20°C~85°C

DRAW	Ku Chou	APPVL	Emily Suen	UNIT	mm	TOLERANCE			泰立電子有限公司 TACLEX ELECTRONICS CO., LTD.	TITLE	M8-4PIN(F)前鎖板線式			SHEET
CHECK	Emily Suen			SCALE	1:1	.x ±0.20 .xx ±0.10 .xxx ±0.05 .xxxx ±0.03 ANGULA ±1°				PART NO.	SEE TABLE A	DWG NO.	QC5171	VERSION