

DIMENSION	TOLERANCE
BELOW 10 mm	± 0.3
10~100 mm	± 0.5
ABOVE 100 mm	± 0.8
ANGLE	± 3°

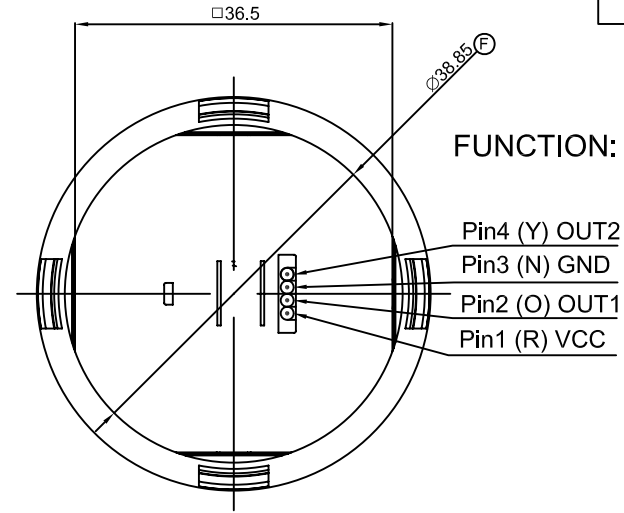

FUNCTION:

- Pin4 (Y) OUT2
- Pin3 (N) GND
- Pin2 (O) OUT1
- Pin1 (R) VCC

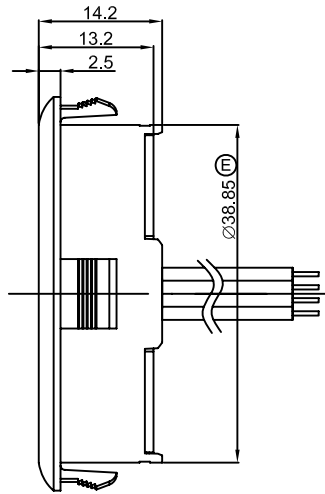
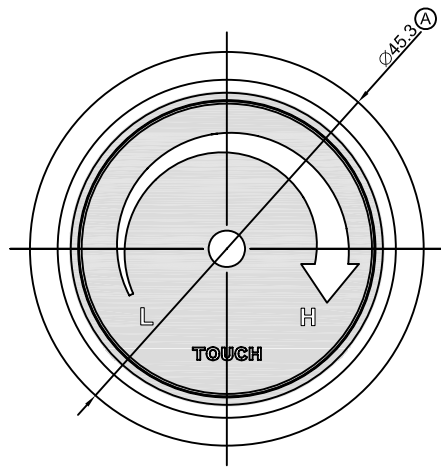
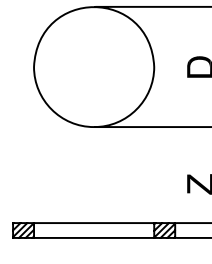
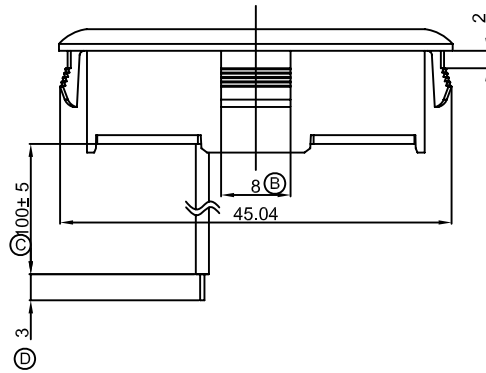

Z	D
1.0 ~ 2.0	43.5~43.7
2.0 ~ 2.5	43.7~44.1
2.5 ~ 3.0	44.1~44.4

SCROLLER OPERATION

A	Encoder - 18 Position Mode
B	Vr - 14 Position Mode
A1	Encoder - 14 Position Mode
B1	Vr - 14 Position Mode

ONE-KYE OPERATION

D	Direct Mode
T	Toggle Mode

CIRCUIT DIAGRAM

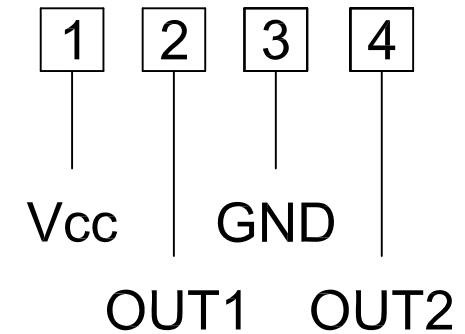

△				DATA	2012/10/25	UNIT	mm	MODE	TACT SWITCH
△				APPROVAL	KAVEN	SCALE	1 : 1	PART	TS005-BTKK301BRBG-W100
△				CONFIRM	TEREANCE	VIEW		2D FILE NAME	TS005-BTKK301BRBG-W100
	DATA	APPROVAL	DESIGN	ENGINEERING CHANGE DESCRIPTION	DESIGN	HQ	VER.	01	3D FILE NAME

DIMENSION	TOLERANCE
BELOW 10 mm	± 0.3
10~100 mm	± 0.5
ABOVE 100 mm	± 0.8
ANGLE	± 3°

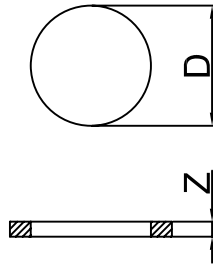
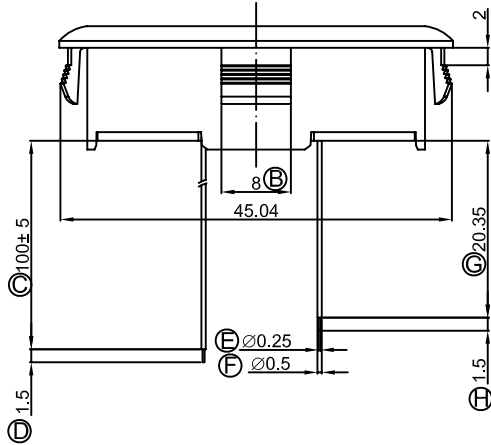
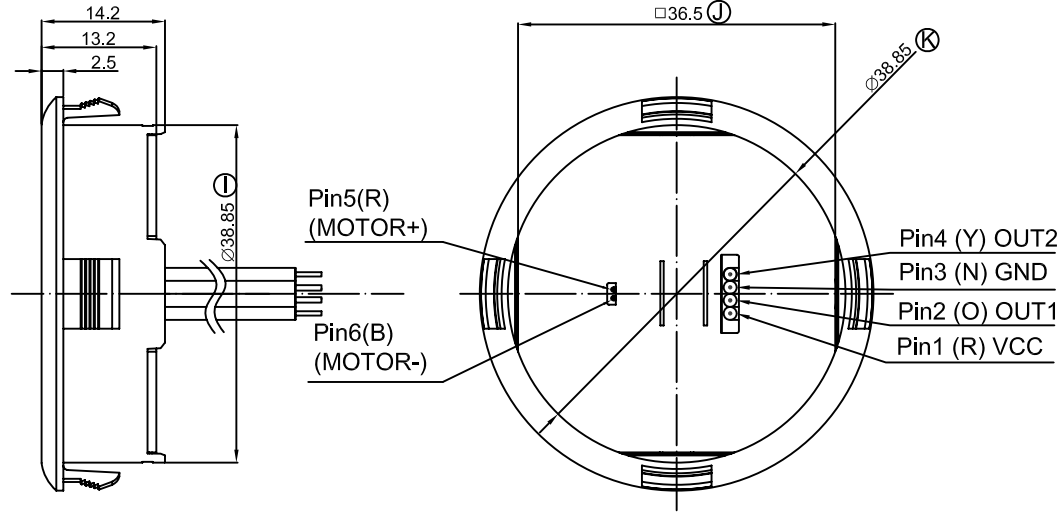
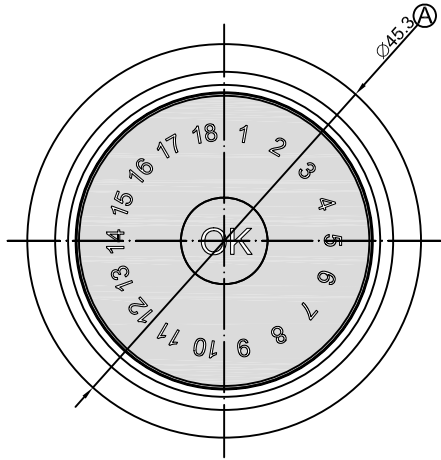

Z	D
1.0 ~ 2.0	43.5~43.7
2.0 ~ 2.5	43.7~44.1
2.5 ~ 3.0	44.1~44.4

### SCROLLER OPERATION

A	Encoder - 18 Position Mode
B	Vr - 14 Position Mode
A1	Encoder - 14 Position Mode
B1	Vr - 14 Position Mode

### ONE-KYE OPERATION

D	Direct Mode
T	Toggle Mode

### CIRCUIT DIAGRAM

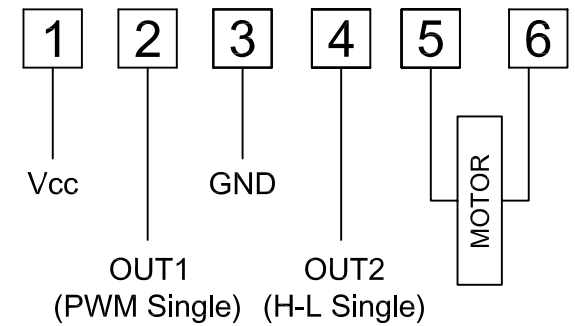

△				DATA	2012/07/9	UNIT	mm	MODE	LED ENCODER & VR
△				APPROVAL	KAVEN	SCALE	1 : 1	PART	TS005-BTMKK201WWW-W100
△				CONFIRM	TEREANCE	VIEW		2D FILE NAME	TS005-BTMKK201WWW-W100
	DATA	APPROVAL	DESIGN	ENGINEERING CHANGE DESCRIPTION	DESIGN	HQ	VER.	01	3D FILE NAME

