

在SL4N型中新追加拉設式(pullreset)系列產品

- 可節省工作步驟，讓更新作業更容易進行的M12接頭新上市
- 採用接觸信賴性極高的Au包層接點，無論是一般負荷或是微小負荷均可對應
- 符合 UL、EN(TUV)、CCC認證規格
- 可對應EN115、EN81-1

Interchanging of switch heads succeeded by easy operation of forked metal latch

- Easily adjustable in 3 planes of switch head.
- Includes one integral connectors or replaces to other connector solution.
- Various contacts became one integral part of switch head to the SLMD series.
- 1/4 return is only required if remove the connection component of SLMD series.
- In relation to switch body all the switch heads could be adjusted in 15° steps throughout 360°.
- Including snap action and slow break contacts, with positive opening operations and interchangeable connection component.

■性能 Characteristics

保護結構	Degree of protection	IP65 conforming to IEC60529 IK 04 conforming to EN50102
符合標準 Conforming to standards	產品 Products	IEC60947-5-1, EN60947-5-1, UL508, CSA C22-2 n° 14
	配件 Machine assemblies	IEC60204-1, EN60204-1
材料	Materials	plastic
重複精度	Repeat accuracy	0.1mm on the tripping points, with 1 million operating cycles for head with end plunger
產品認證	Product certifications	UL, CSA, CCC(pending)
保護處理	Protective treatment	Standard "TC"
抗振性	Vibration resistance	25 gn (10...500Hz)
抗電氣沖擊性能	Electric shock protection	Class II conforming to IEC61140 and NFC20030
額定工作特性	Rated operational characteristics	~AC-15;A300(Ue = 240 V, Ie = 3A);1the = 10A ∴ DC-13;Q300(Ue = 250 V, Ie = 0.27A), conforming to IEC60947-5-1 Appendix A, EN60947-5-1
額定絕緣電壓 (Ui) Rated insulation voltage (Ui)	2-pole contact	Ui = 500 V degree of pollution 3 conforming to IEC60947-1 Ui = 300 V vonforming to UL508, CSA C22-2 n° 14
額定沖擊耐 受電壓 Rated impulse withstand voltage	2-pole contact	U imp = 6 kV conforming to IEC60947-1, IEC60664
肯定斷開操作	Positive operation (Depending on model)	N/C contacts with positive opening operation conforming to IEC60947-5-1 Appendix K, EN60947-5-1
短路保護	Electric shock protection	10 A cartridge fuse type gG(gl)
環境溫度 Ambient air temperature	操作 Operation	-25~+70°C
	儲存 Storage	-40~+70°C
包裝說明	Packing	10pcs /Box

★備註 1.以上為初始值 2.上述性能內容將因機種型式而有所不同.請另行洽詢 3.上述壽命值是為周圍溫度5-35度C，周圍濕度40-70%RH時之條件。如您需要其它詳細條件，請另行洽詢。

★Note: 1. Above values of these characteristics are initial values. 2. Above values of these characteristics may be depending on different models. If any requirements, pls contact our DECA sales representative. 3. Above durability is for an ambient temperature of 5 to 35°C and ambient humidity of 40% to 70%. If any requirements, pls contact our DECA sales representative.

SLNR-00

- 標準柱塞型
Standard Pin Plunger

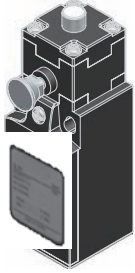

重量 Weight: 80.00g

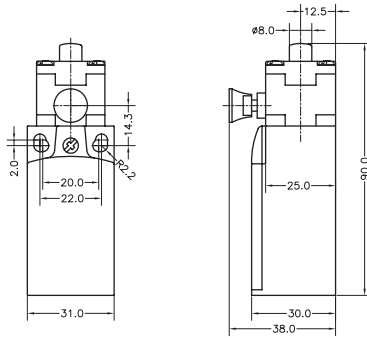

SLNR-00	
LF	10.8N
LT	4.5mm
PT1	2mm
OP (TT)	33.5 ± 0.5mm (6mm)
DOT	3.2mm
DOF	20N

SLNR-20

- 標準滾輪柱塞型
Standard Roller Plunger

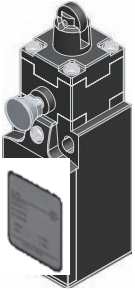

重量 Weight: 81.50g

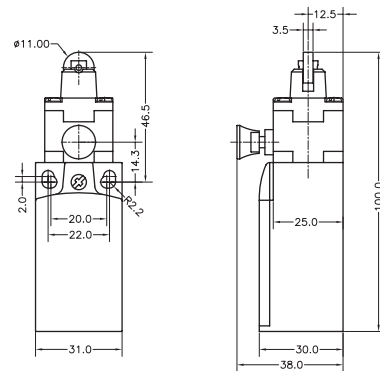

SLNR-20	
LF	10.8N
LT	4.5mm
PT1	2mm
OP (TT)	43.6 ± 0.5mm (6mm)
DOT	3.2mm
DOF	20N

SLNR-52

- 面板安裝柱塞型
Unidirectional Horizontal
Action Hinge Roller Lever

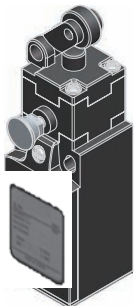

重量 Weight: 80.20g

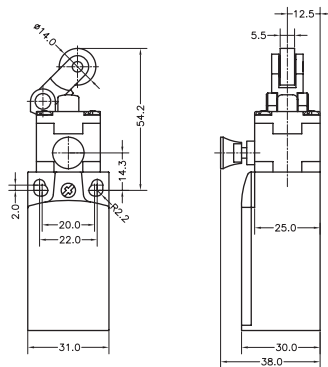

SLNR-52	
LF	7.5N
LT	7mm
PT1	4mm
OP (TT)	50.2 ± 0.8mm (9mm)
DOT	5.8mm
DOF	20N

SLNR-53

- 面板安裝滾輪柱塞型
Unidirectional Vertical
Action Hinge Roller Lever

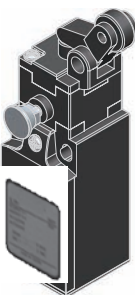

重量 Weight: 80.10g

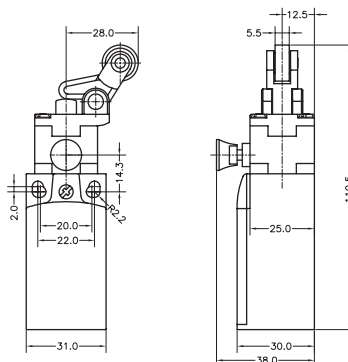

SLNR-53	
LF	7.9N
LT	7mm
PT1	4mm
OP (TT)	52 ± 0.8mm (9mm)
DOT	4.8mm
DOF	20N