



### SPECIFICATIONS

**CONTACT RATING:** Dependent upon contact material See page 18.

**MECHANICAL LIFE:** 30,000 make-and-break cycles.

**CONTACT RESISTANCE:** 10mΩ max. initial @ 2-4VDC  
100mA for both silver and gold plated contacts.

**INSULATION RESISTANCE:** 1,000MΩ min.

**DIELECTRIC STRENGTH:** 1,000 V RMS@sea level.

**OPERATING TEMPERATURE:** -30°C to 85°C.

### MATERIALS

**CASE & BUSHING:** Glass filled nylon 66, flame retardant, heat stabilized (UL94V-0)

**ACTUATOR:** Brass, chrome plated with internal O-ring seal standard.

**SWITCH SUPPORT:** Brass or steel, tin plated.

**SWITCH SUPPORT RETAINER:** Stainless steel.

**CONTACTS/TERMINALS:** copper alloy, with silver or gold plated. (See Page 18)

## HOW TO ORDER

MODEL NO.	ACTUATOR	BUSHING	TERMINATIONS	CONTACT MATERIAL	SEAL	ROHS SOLDERING																																																																																																																																																							
<table border="0"> <tr> <td>□</td><td>□</td><td>□</td><td>□</td><td>□</td><td>□</td><td>□</td> </tr> <tr> <td>MODEL NO.</td> <td>ACTUATOR</td> <td>BUSHING</td> <td>TERMINATIONS</td> <td>CONTACT MATERIAL</td> <td>SEAL</td> <td>ROHS SOLDERING</td> </tr> </table>	□	□	□	□	□	□	□	MODEL NO.	ACTUATOR	BUSHING	TERMINATIONS	CONTACT MATERIAL	SEAL	ROHS SOLDERING	<table border="0"> <tr> <td>T1</td><td>12.70 high</td> <td>B1</td><td>8.80 high</td> <td>Q</td><td>Silver</td> <td>E</td><td>EPOXY (std)</td> </tr> <tr> <td>T2</td><td>7.62 high</td> <td>B4</td><td>6.10 high</td> <td>R</td><td>Gold</td> <td></td><td></td> </tr> <tr> <td>TA</td><td>plastic, anti-static, black 12.70 high</td> <td></td><td></td> <td>G</td><td>Gold, pure-tin</td> <td></td><td></td> </tr> <tr> <td>TB</td><td>plastic, anti-static black 7.62 high</td> <td></td><td></td> <td>S</td><td>Silver, pure-tin</td> <td></td><td></td> </tr> <tr> <td>TC</td><td>plastic, anti-static silver 12.70 high</td> <td></td><td></td> <td>C</td><td>Gold over silver</td> <td></td><td></td> </tr> </table>	T1	12.70 high	B1	8.80 high	Q	Silver	E	EPOXY (std)	T2	7.62 high	B4	6.10 high	R	Gold			TA	plastic, anti-static, black 12.70 high			G	Gold, pure-tin			TB	plastic, anti-static black 7.62 high			S	Silver, pure-tin			TC	plastic, anti-static silver 12.70 high			C	Gold over silver			<table border="0"> <tr> <td>M1</td><td>Solder Lug</td> <td></td><td></td> <td>K</td><td>Gold over silver, pure-tin</td> <td></td><td></td> </tr> <tr> <td>M2</td><td>PC thru-hole</td> <td></td><td></td> <td></td><td></td> <td></td><td></td> </tr> <tr> <td>M5-1</td><td>18.70 high, wire wrap</td> <td></td><td></td> <td></td><td></td> <td></td><td></td> </tr> <tr> <td>M5-2</td><td>24.20 high, wire wrap</td> <td></td><td></td> <td></td><td></td> <td></td><td></td> </tr> <tr> <td>M5-3</td><td>10.55 high, wire wrap</td> <td></td><td></td> <td></td><td></td> <td></td><td></td> </tr> <tr> <td>M5-4</td><td>26.97 high, wire wrap</td> <td></td><td></td> <td></td><td></td> <td></td><td></td> </tr> <tr> <td>M6</td><td>Right angle, PC thru-hole</td> <td></td><td></td> <td></td><td></td> <td></td><td></td> </tr> <tr> <td>M6N</td><td>Right angle, snap-in, PC thru-hole</td> <td></td><td></td> <td></td><td></td> <td></td><td></td> </tr> <tr> <td>M7</td><td>Vertical right angle, PC thru-hole</td> <td></td><td></td> <td></td><td></td> <td></td><td></td> </tr> <tr> <td>VS2</td><td>11.68 high, V-bracket</td> <td></td><td></td> <td></td><td></td> <td></td><td></td> </tr> <tr> <td>V2N</td><td>11.68 high, snap-in V-bracket</td> <td></td><td></td> <td></td><td></td> <td></td><td></td> </tr> <tr> <td>VS3</td><td>16.00 high, V-bracket</td> <td></td><td></td> <td></td><td></td> <td></td><td></td> </tr> </table>	M1	Solder Lug			K	Gold over silver, pure-tin			M2	PC thru-hole							M5-1	18.70 high, wire wrap							M5-2	24.20 high, wire wrap							M5-3	10.55 high, wire wrap							M5-4	26.97 high, wire wrap							M6	Right angle, PC thru-hole							M6N	Right angle, snap-in, PC thru-hole							M7	Vertical right angle, PC thru-hole							VS2	11.68 high, V-bracket							V2N	11.68 high, snap-in V-bracket							VS3	16.00 high, V-bracket							<table border="0"> <tr> <td>□</td><td>RoHS Compliant</td> </tr> <tr> <td>S</td><td>RoHS &amp; Lead Free</td> </tr> </table>	□	RoHS Compliant	S	RoHS & Lead Free
□	□	□	□	□	□	□																																																																																																																																																							
MODEL NO.	ACTUATOR	BUSHING	TERMINATIONS	CONTACT MATERIAL	SEAL	ROHS SOLDERING																																																																																																																																																							
T1	12.70 high	B1	8.80 high	Q	Silver	E	EPOXY (std)																																																																																																																																																						
T2	7.62 high	B4	6.10 high	R	Gold																																																																																																																																																								
TA	plastic, anti-static, black 12.70 high			G	Gold, pure-tin																																																																																																																																																								
TB	plastic, anti-static black 7.62 high			S	Silver, pure-tin																																																																																																																																																								
TC	plastic, anti-static silver 12.70 high			C	Gold over silver																																																																																																																																																								
M1	Solder Lug			K	Gold over silver, pure-tin																																																																																																																																																								
M2	PC thru-hole																																																																																																																																																												
M5-1	18.70 high, wire wrap																																																																																																																																																												
M5-2	24.20 high, wire wrap																																																																																																																																																												
M5-3	10.55 high, wire wrap																																																																																																																																																												
M5-4	26.97 high, wire wrap																																																																																																																																																												
M6	Right angle, PC thru-hole																																																																																																																																																												
M6N	Right angle, snap-in, PC thru-hole																																																																																																																																																												
M7	Vertical right angle, PC thru-hole																																																																																																																																																												
VS2	11.68 high, V-bracket																																																																																																																																																												
V2N	11.68 high, snap-in V-bracket																																																																																																																																																												
VS3	16.00 high, V-bracket																																																																																																																																																												
□	RoHS Compliant																																																																																																																																																												
S	RoHS & Lead Free																																																																																																																																																												

### SWITCH FUNCTION

NO. POLES	UL/CSA MODEL NO.	MODEL NO.	SWITCH FUNCTION			CONNECTED TERMINALS / SCHEMATIC		
			POS.1	POS.2	POS.3	POS.1	POS.2	POS.3
SP	Q11A11	1AS1	ON	NONE	ON		N/A	
	Q11A12	1AS2	ON	NONE	MOM			
	Q11A13	1AS3	ON	OFF	ON			
	Q11A14	1AS4	MOM	OFF	MOM			
	Q11A15	1AS5	ON	OFF	MOM			
DP	Q11A21	1AD1	ON	NONE	ON		N/A	
	Q11A22	1AD2	ON	NONE	MOM			
	Q11A23	1AD3	ON	OFF	ON			
	Q11A24	1AD4	MOM	OFF	MOM			
	Q11A25	1AD5	ON	OFF	MOM			
	Q11A26	1AD6	ON	ON	ON			
	▲ Q11A27	1AD7	MOM	ON	MOM			
	▲ Q11A28	1AD8	ON	ON	MOM			
3P	Q11A31	1A31	ON	NONE	ON		N/A	
	Q11A32	1A32	ON	NONE	MOM			
	Q11A33	1A33	ON	OFF	ON			
	Q11A34	1A34	MOM	OFF	MOM			
	Q11A35	1A35	ON	OFF	MOM			

MOM=MOMENTARY

▲ Please check the availability in advance before order

### POLE OPTIONS



SPDT

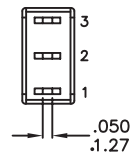
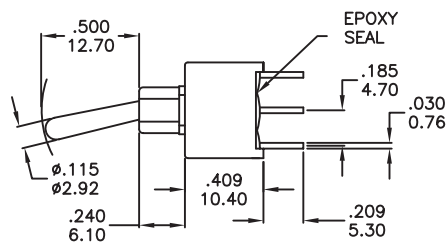
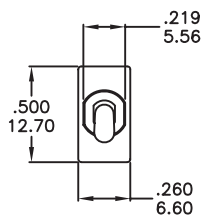

Part No. Shown : 1AS1T1B4M2RE

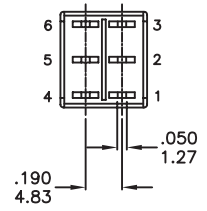
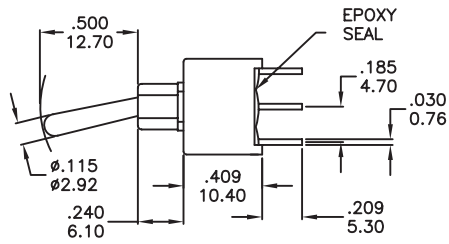
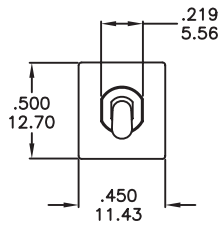

**DPDT**

Part No. Shown : 1AD1T1B4M2RE

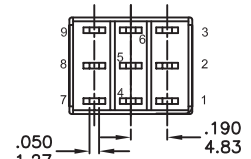
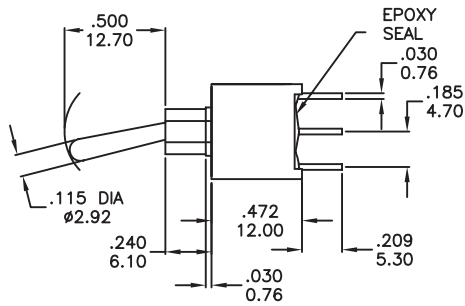
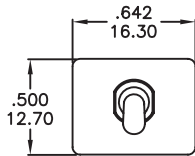

**3PDT**

Part No. Shown : 1A31T1B4M2RE

### ACTUATOR OPTIONS

Actuator shown with standard B4 Bushing, Subtract .085(2.15) for B1 bushing.

**T1**

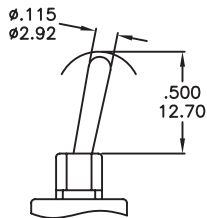

Standard with M1,M2 terminations.

**T2**

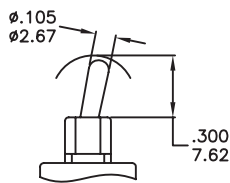

Standard with M6,M7,VS2-3 terminations.

**TA & TC**

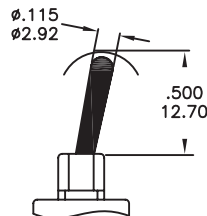

ESD PLASTIC ACTUATOR (TC anti-static,silver)

**TB**

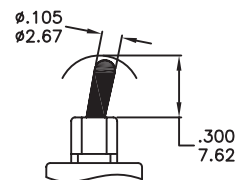

### BUSHING OPTIONS

**B1**

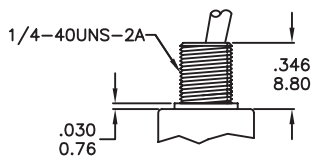

Std for M1

**B4**



Std for M2, M6, M7, VS termination

### TERMINATION OPTIONS

#### M1 SOLDER LUG

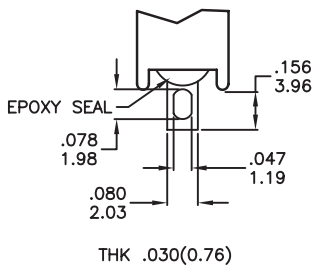

#### M2 PC THRU-HOLE

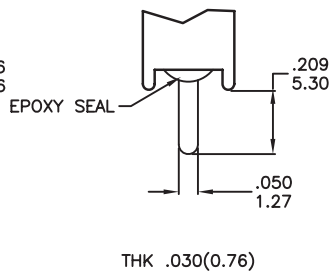

#### M3 QUICK CONNECT

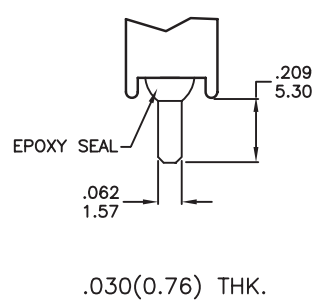

#### M5 WIRE WRAP

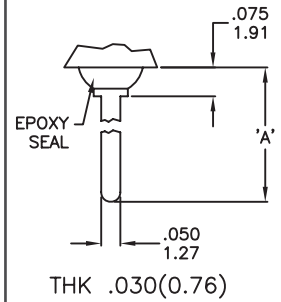

#### OTHER TERMINATION OPTIONS

- M6 RIGHT ANGLE P.C. MOUNT
- M7 RIGHT ANGLE P.C. MOUNT
- VS2 VERTICAL BRACKET P.C. MOUNT
- VS3 VERTICAL BRACKET P.C. MOUNT

RE Mating Quick Connector  
Amp P/N 60900-1

OPTION CODE	DIM. 'A'
M5-1	.736(18.70)
M5-2	.953(24.20)
M5-3	.415(10.55)
M5-4	1.062(26.97)

#### M6

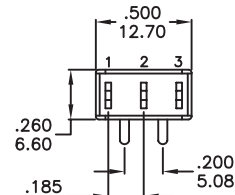
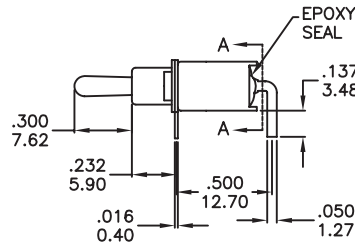
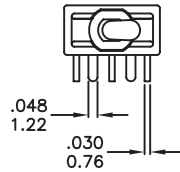

#### P.C. MOUNTING

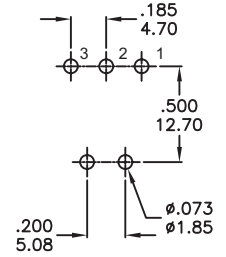

Part No. Shown : 1AS1T2B4M6RE

SECTION A-A  
TERM. NOS. FOR  
REFERENCE ONLY

#### SPDT

#### M6

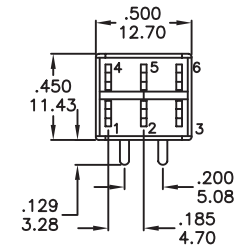
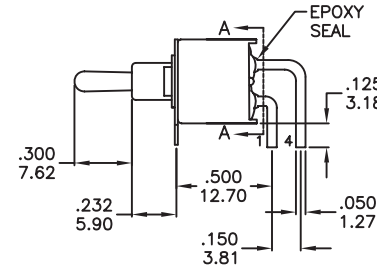
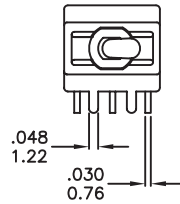

#### P.C. MOUNTING

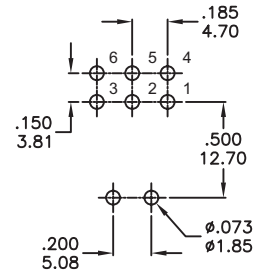

Part No. Shown : 1AD1T2B4M6RE

SECTION A-A  
TERM. NOS. FOR  
REFERENCE ONLY

#### DPDT

#### M7

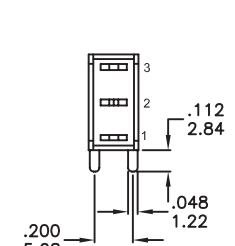
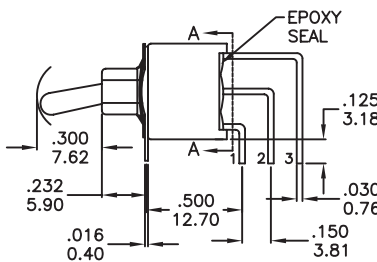
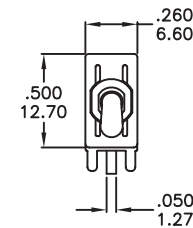
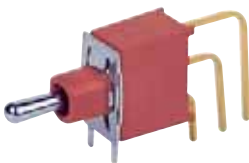

#### P.C. MOUNTING

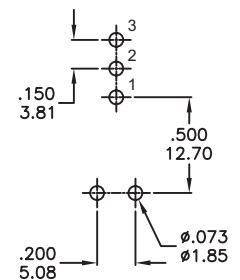

Part No. Shown : 1AS1T2B4M7RE

SECTION A-A  
TERM. NOS. FOR  
REFERENCE ONLY

#### SPDT

M7

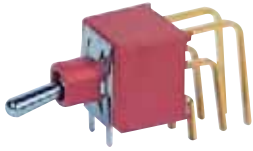

DPDT

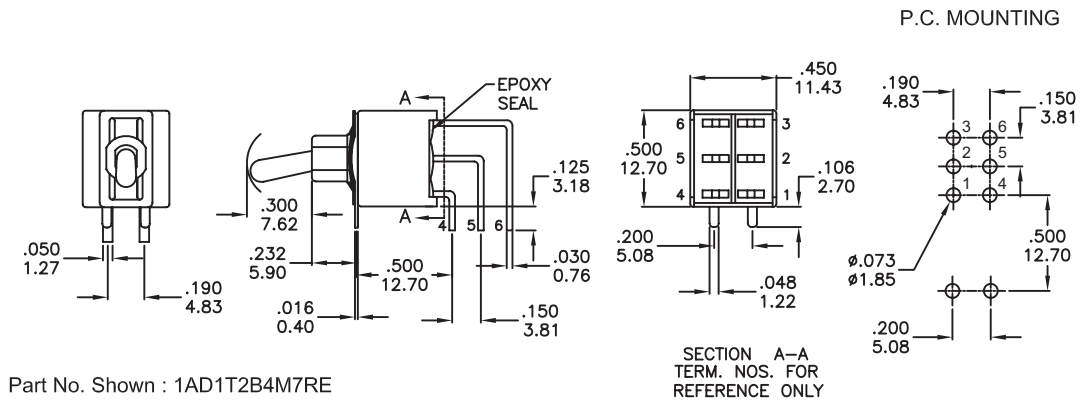

M7

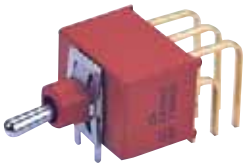

3PDT

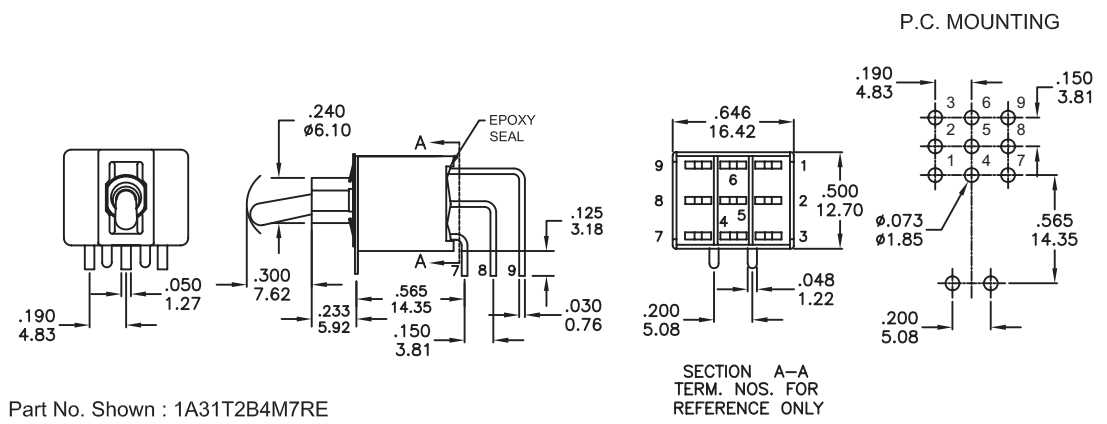

VS2-VS3



SPDT

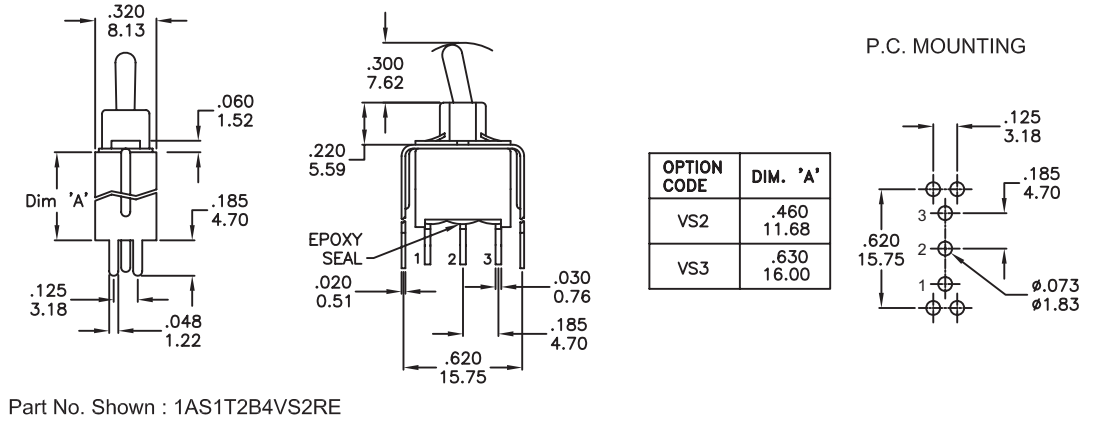

VS2-VS3



DPDT

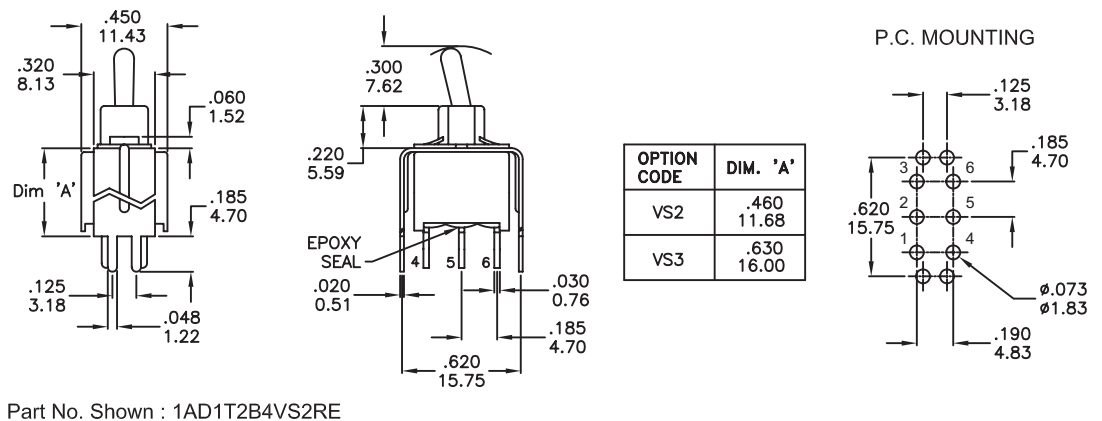

# 1A Series

## Sealed Miniature Toggle Switches

VS2-VS3



3PDT

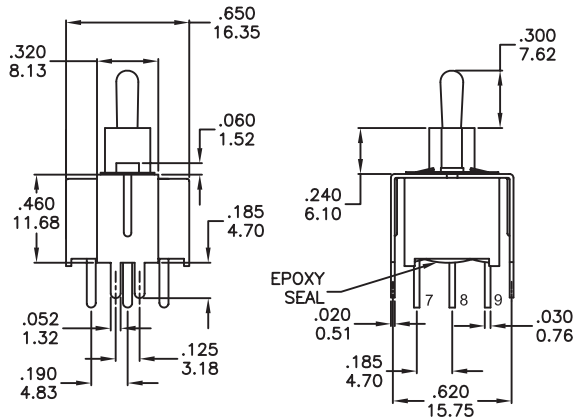

OPTION CODE	DIM. 'A'
VS2	.460 11.68
VS3	.630 16.00

P.C. MOUNTING

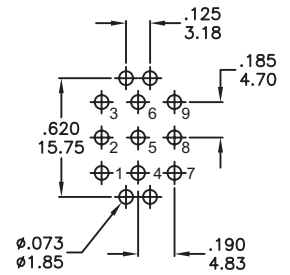

Part No. Shown : 1A31T2B4VS2RE

### SNAP-IN TERMINATION OPTIONS

M6N

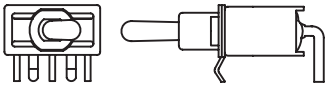

M7N

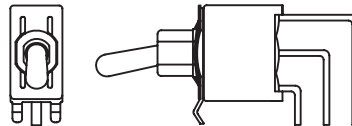

V2N

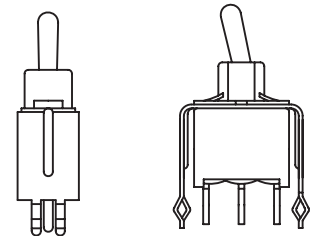

### HARDWARE

NUT

HDW2

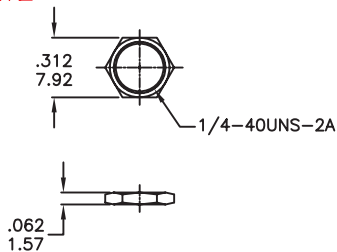

LOCKING RING

HDW15

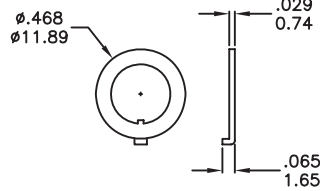

LOCK WASHER

HDW11

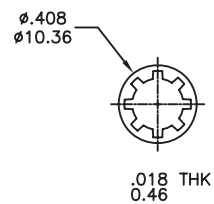

### CONTACT MATERIAL OPTIONS

CONTACT MATERIAL	TERMINATION RATING	RATINGS
<b>Q</b>	<b>Silver</b>	5 Amps with resistant load @ 120VAC or 28VDC 2 Amps with resistant load @ 250VAC
<b>S</b>		
<b>C</b>	<b>Gold over Silver</b>	
<b>K</b>		
<b>R</b>	<b>Gold</b>	0.4 Volt-Amps(VA)max. @ 20V max. (AC or DC)
<b>G</b>		



**IP 67**  
 ACCORDING TO  
 EN 60529:1991+A1:2001  
 IEC 60529:2001

### SOLDERING PROCESSES

**MANUAL SOLDERING** : Use soldering iron of 30 watts, controlled at 350°C approximately 5 seconds while applying solder.

**WAVE SOLDERING** : Recommended Soldering Temperature: 260±5°C  
 Duration of Solder Immersion: 5 ±1 seconds  
 (PCB is 1.6mm in thickness)

**SOLDERING** : Vapor phase

### Temperature Profile

Zone	Room temperature	Time ( Sec )
Pre-heat ( A )	150°C	Min 120s
Soak ( B )	180°C~200°C	Min 150s
Peak ( C )	200°C~235°C	Min 30s
Peak ( D )	235°C~260°C	Min 40s
Peak ( E )	260°C	Max 10s

