

MPT SERIES

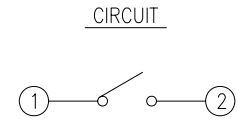

DIMENSIONS

MPTCFGP1

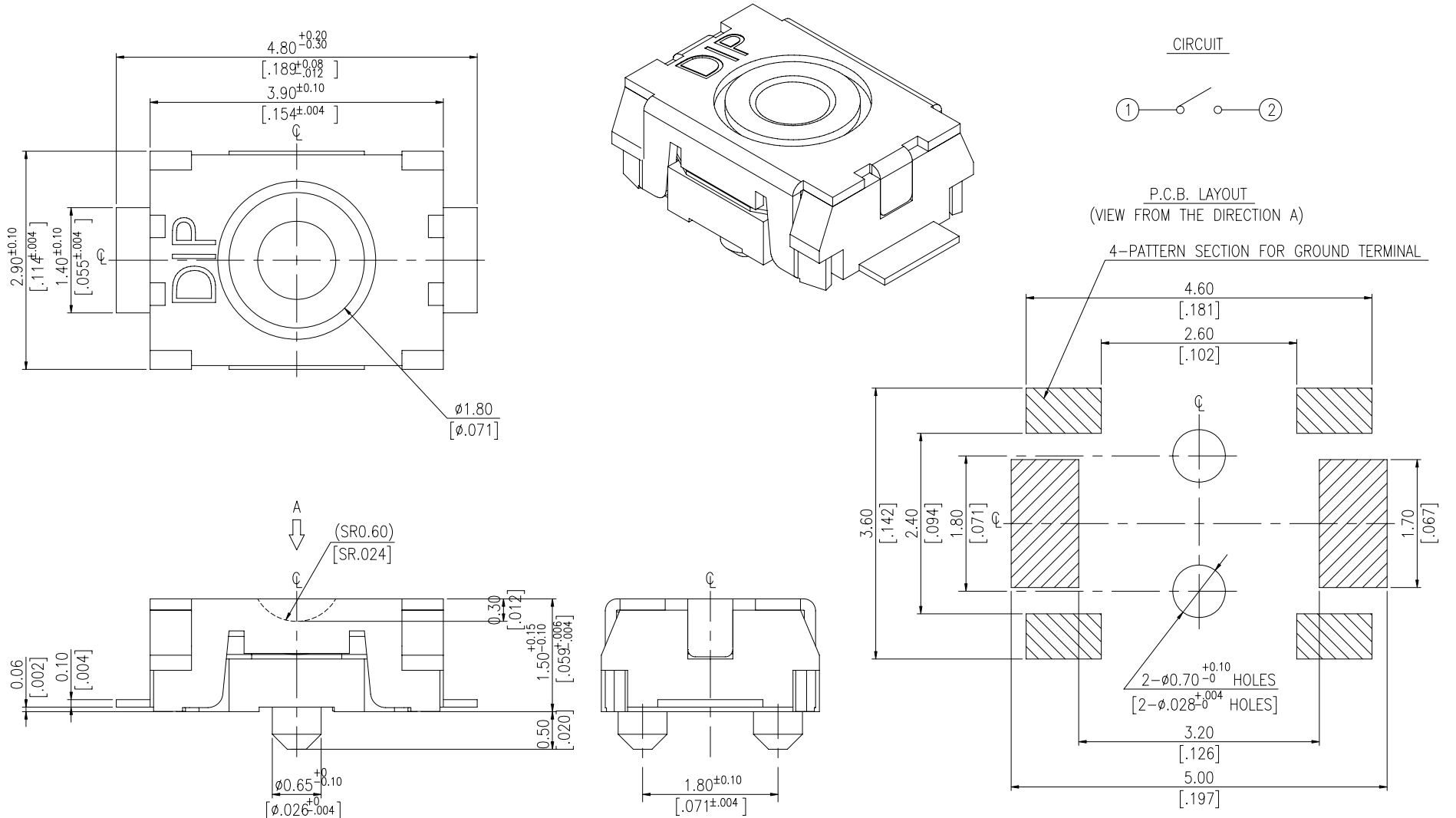

P.C.B. LAYOUT
(VIEW FROM THE DIRECTION A)

4-PATTERN SECTION FOR GROUND TERMINAL

HATCHED AREA SHOWS SOLDERING LAND

General Tolerance : $\pm 0.2\text{mm}$

MPTCLGP2

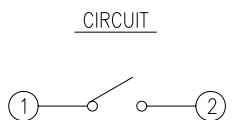
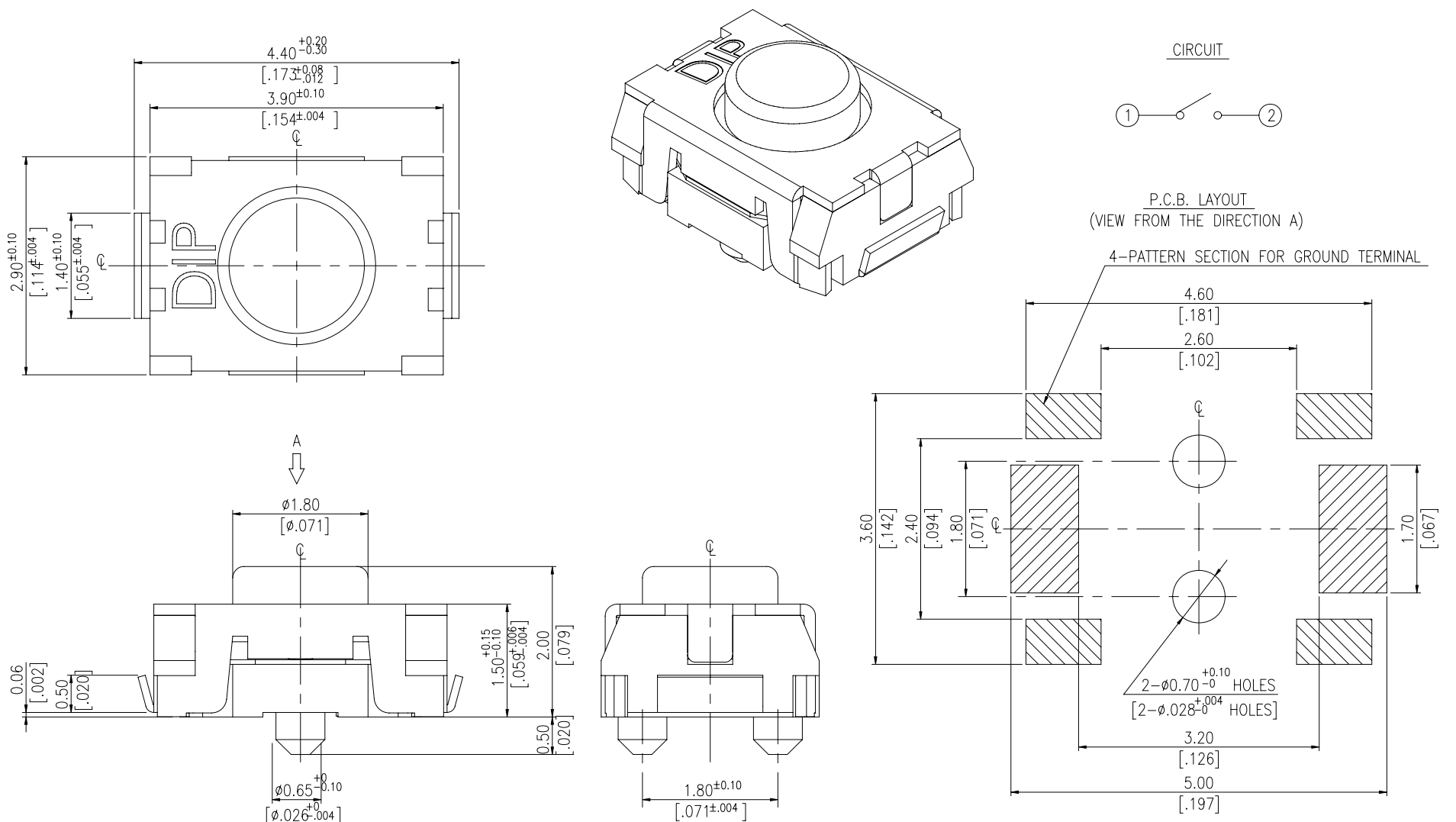

P.C.B. LAYOUT
(VIEW FROM THE DIRECTION A)

4-PATTERN SECTION FOR GROUND TERMINAL

HATCHED AREA SHOWS SOLDERING LAND

General Tolerance : $\pm 0.2\text{mm}$

MPTCLG

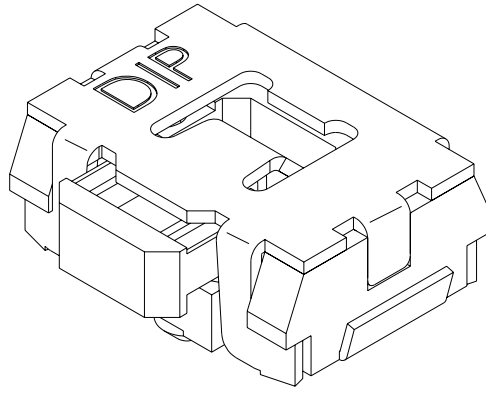
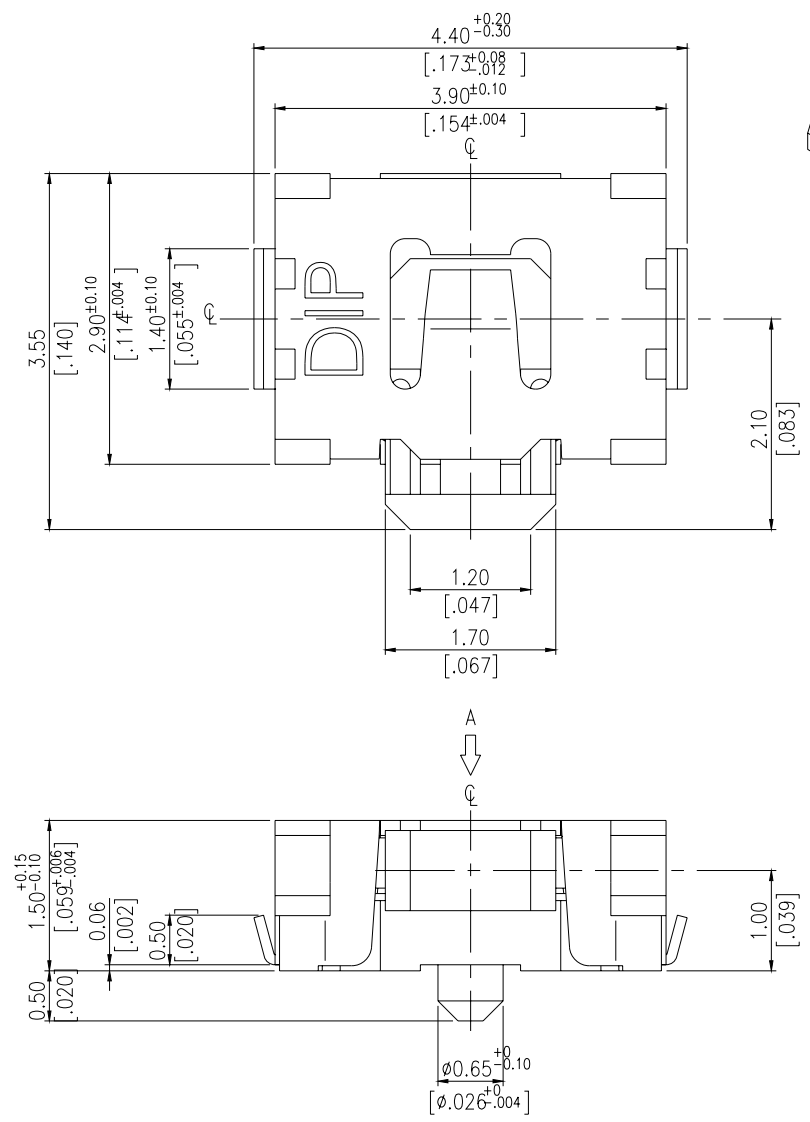

CIRCUIT

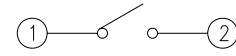

P.C.B. LAYOUT
(VIEW FROM THE DIRECTION A)

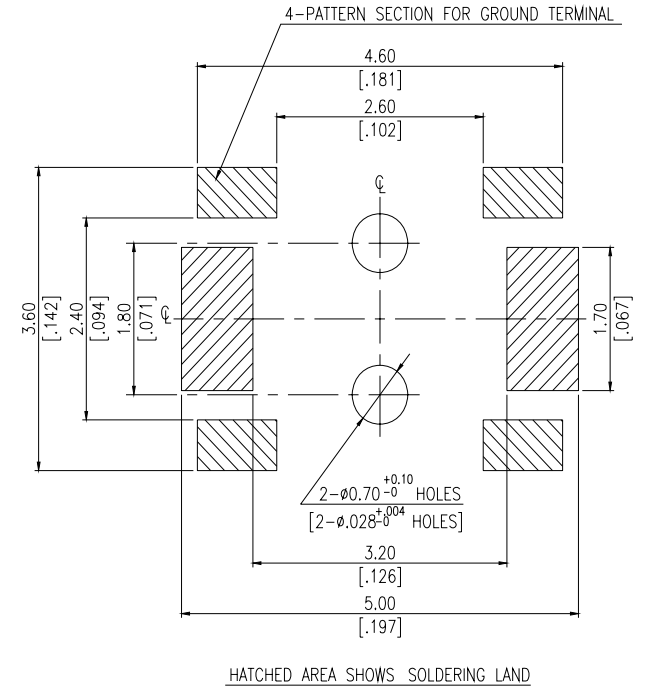

General Tolerance : $\pm 0.2\text{mm}$

MPTCFG

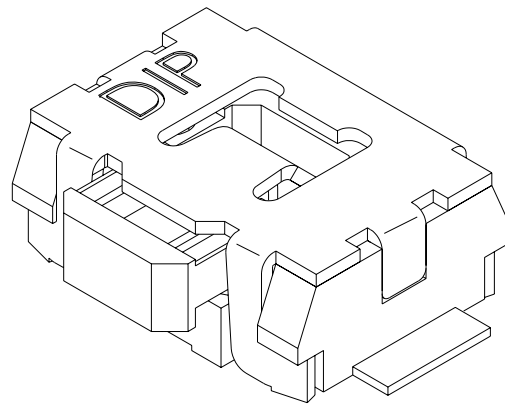
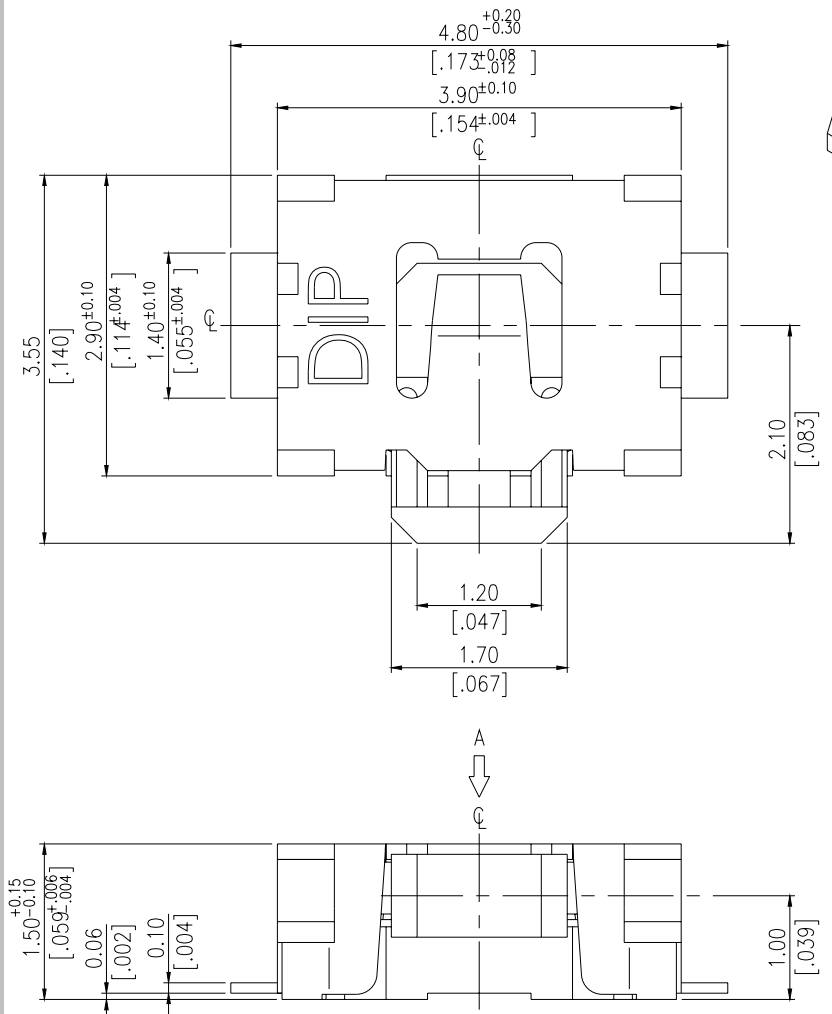

CIRCUIT

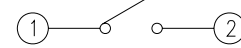

P.C.B. LAYOUT
(VIEW FROM THE DIRECTION A)

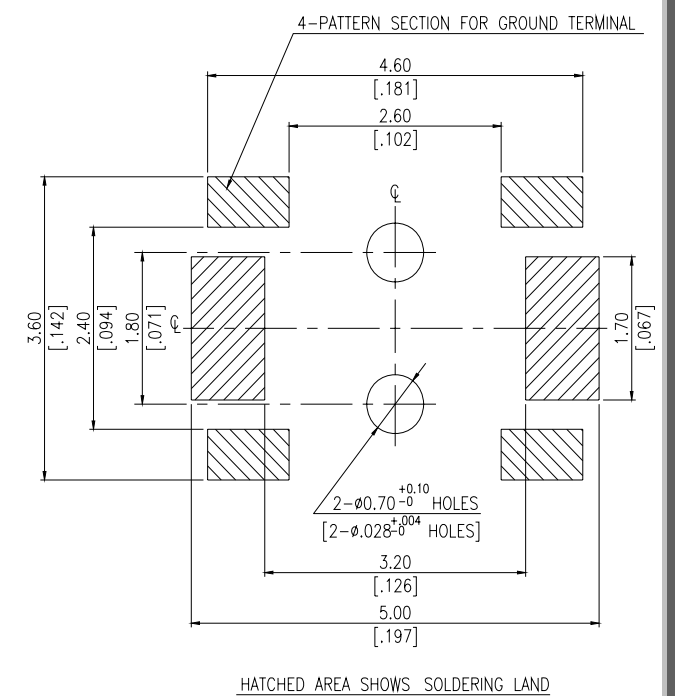

General Tolerance : $\pm 0.2\text{mm}$

HOW TO ORDER

MPT □ □ □ □ - □ - □

Package Style:
T/R=Tape & Reel

Soldering:
V=Lead Free Solderable

Stem Height for Vertical Push Type
□=Side Push
P1=1.5mm
P2=2.0mm

G=Ground Terminal
□=Without Ground Terminal

Terminal Type:
F=With Flat Terminal
L= With Bending Terminal

Pilot:
□= Without Pilot
C = With Pilot

Miniature side/ Vertical Push Switch

SPECIFICATION

△MECHANICAL

Operation Force: 160 ± 50gf Vertical Push
220 ± 65gf Side push

Stroke: 0.2 +0.10 / - 0.05 mm side push
0.13 +0.10/-0.05 mm Vertical push

Operation Temperature: -25°C to + 70°C

Storage Temperature: -30°C to +80°C

△ELECTRICAL

Electrical Life: 100,000 cycles (Side push)

Electrical Life: 200,000 cycles (Vertical push)

Rating:50mA , 12VDC

Contact Resistance: 100mΩ max.

Insulation Resistance: 100MΩ min. at 100VDC

Dielectric Strength: 100VAC/1 minute

Contact Arrangement: 1 pole 1 throw

MATERIAL

△COVER: Stainless steel

△BASE: LCP High-temp thermoplastic
Color: White

△STEM: LCP High-temp thermoplastic
Color: Black

△CONTACT DISC: Stainless with silver cladding

△TERMINAL: Brass with silver plated

△TAPE: Teflon

SOLDERING PROCESS

△HAND SOLDERING : Use a soldering iron of 30 watts, controlled at 350°C approximately max 5 seconds while applying.

△REFLOW SOLDERING: When applying reflow soldering, the peak temperature or the reflow oven should be set to 260°C max.

△Reflow Temperature Profile:

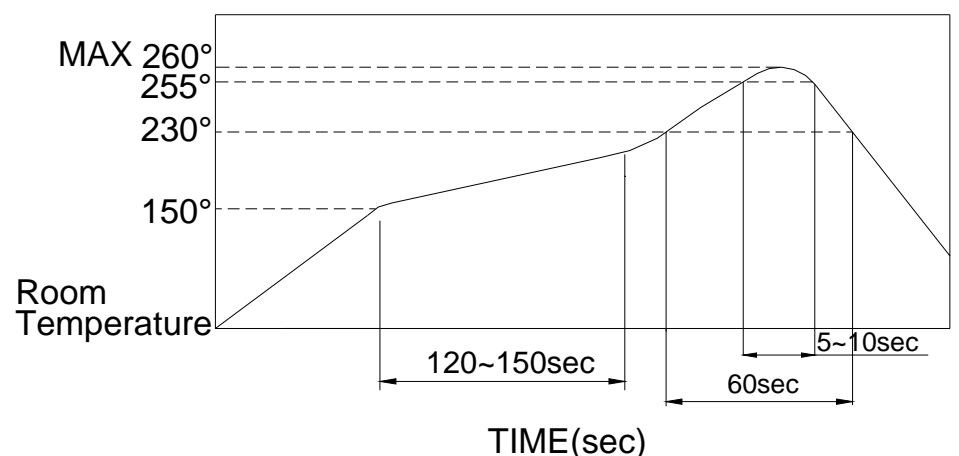

PACKING

Part Number	Number Per Reel
MPT□FG	3500
MPT□LG	3500
MPT□F□P1	2000
MPT□L□P2	2000

MPT REEL

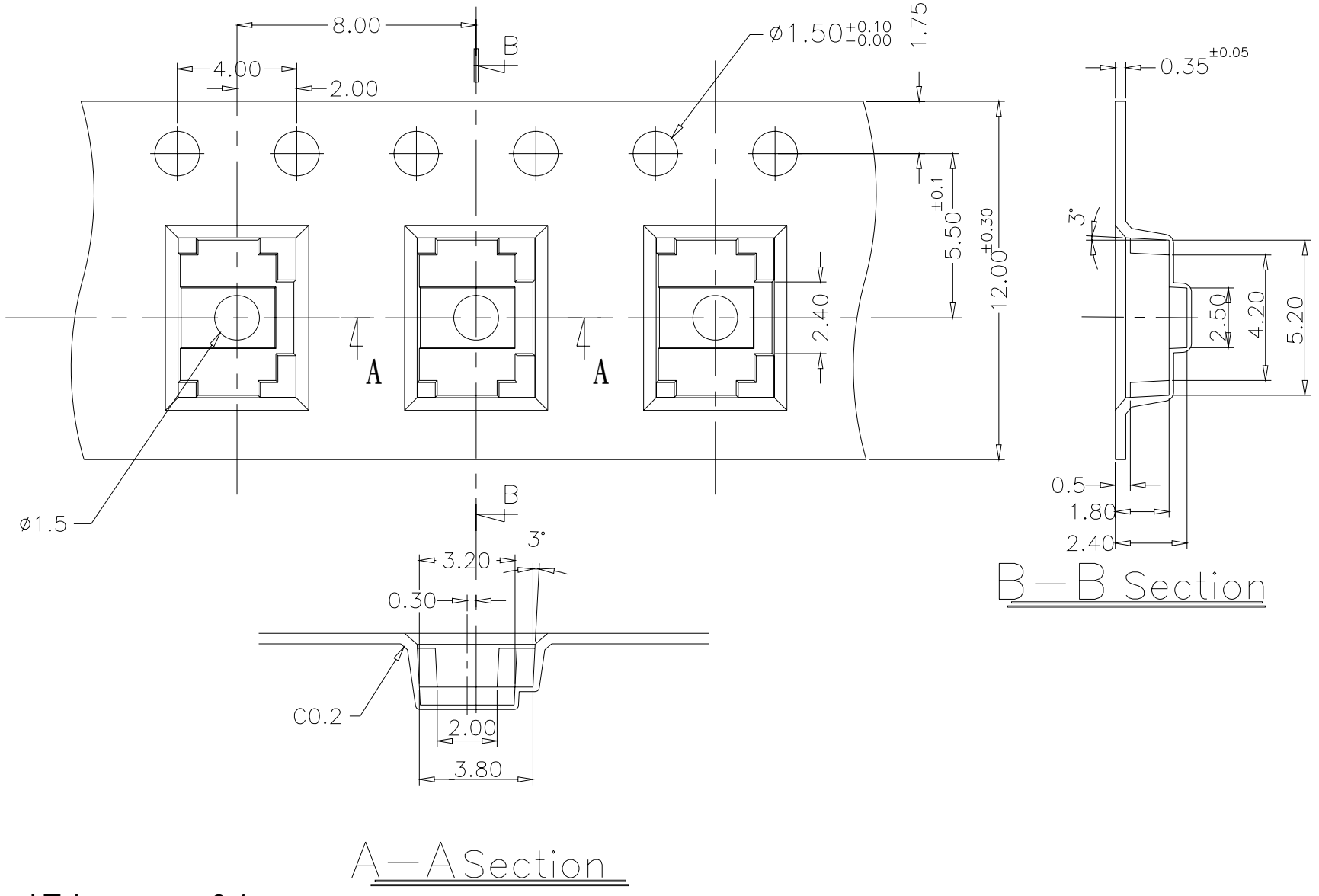

General Tolerance : ±0.1mm

MPT□F□P1、P2 REEL

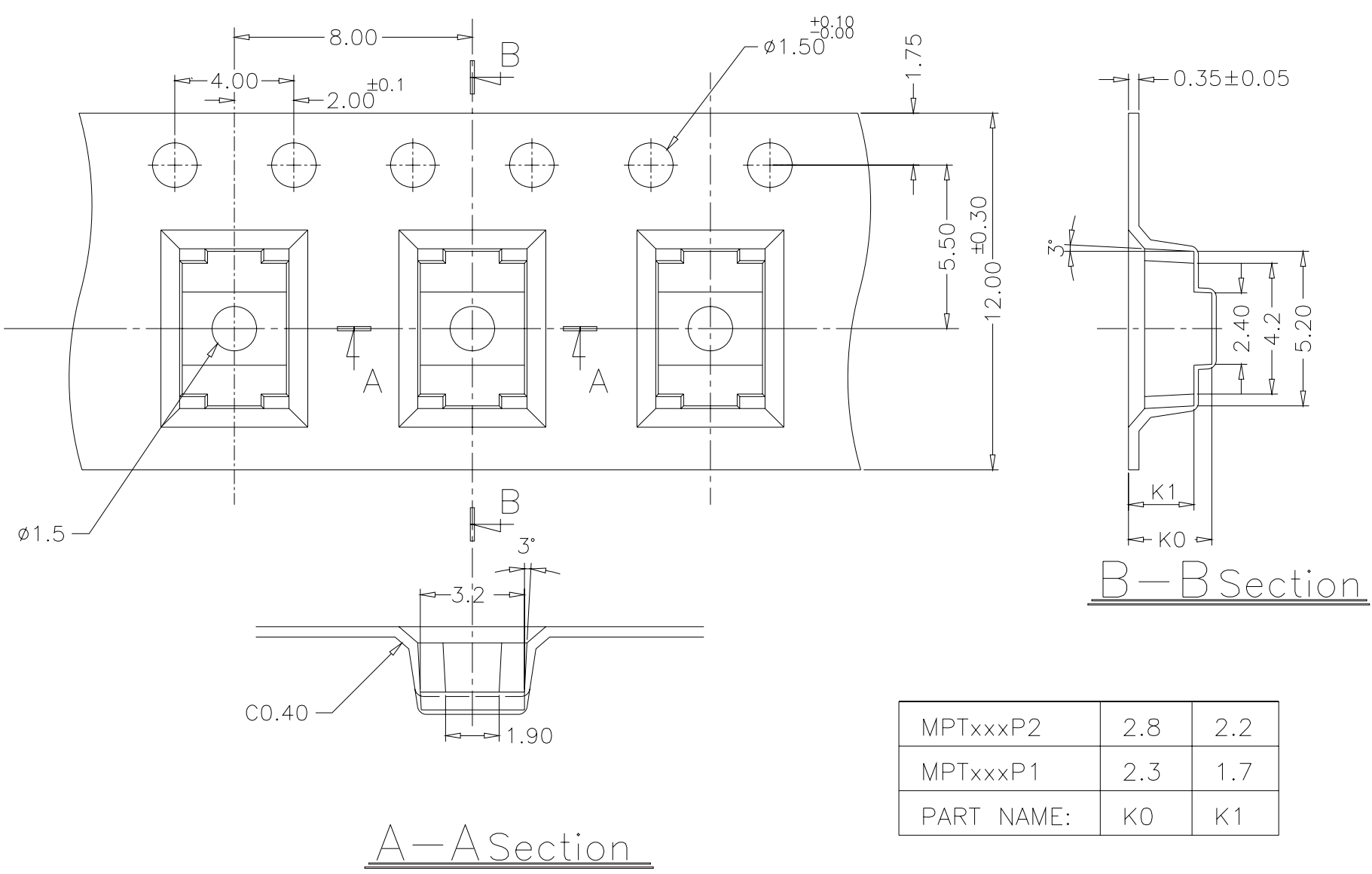

MPTxxxP2	2.8	2.2
MPTxxxP1	2.3	1.7
PART NAME:	K0	K1

General Tolerance : ±0.1mm