

TII(R) & TIM(R) SERIES

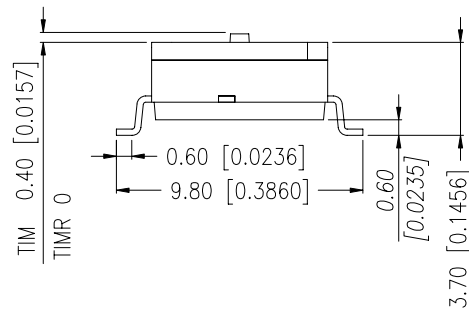

DIMENSIONS

TIM(R)

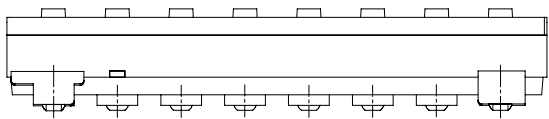
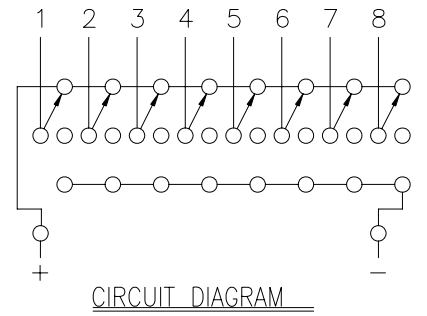
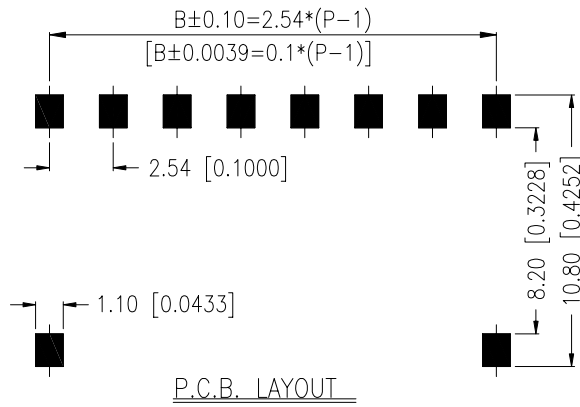
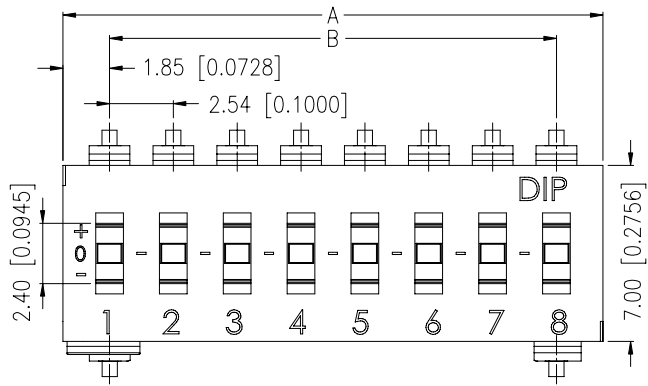

TIM-10	10	26.56[1.046]	22.86[.900]
TIMR-10	10	26.56[1.046]	22.86[.900]
TIM-09	9	24.02[.946]	20.32[.800]
TIMR-09	9	24.02[.946]	20.32[.800]
TIM-08	8	21.48[.846]	17.78[.700]
TIMR-08	8	21.48[.846]	17.78[.700]
TIM-04	4	11.32[.446]	7.62[.300]
TIMR-04	4	11.32[.446]	7.62[.300]
PROD. NO.	NO. OF POS.	DIM. A	DIM. B

General Tolerance : $\pm 0.2\text{mm}$

TII(R)

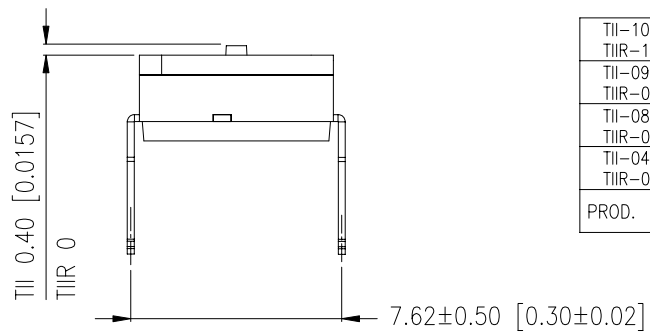
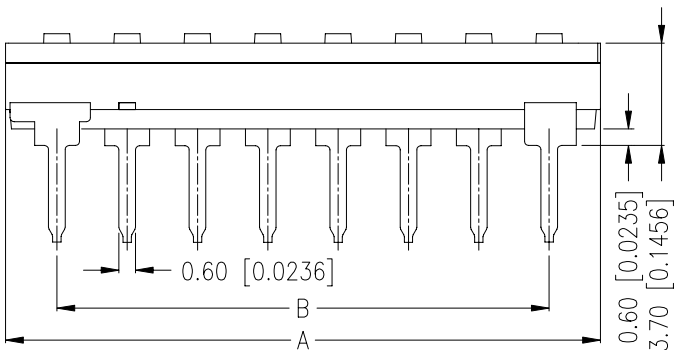
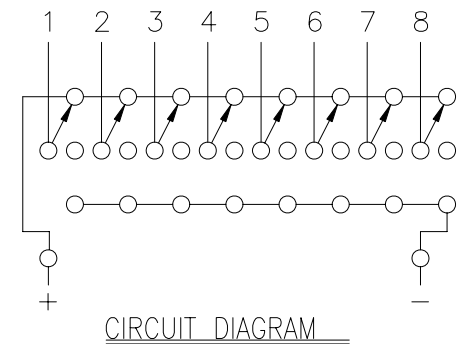
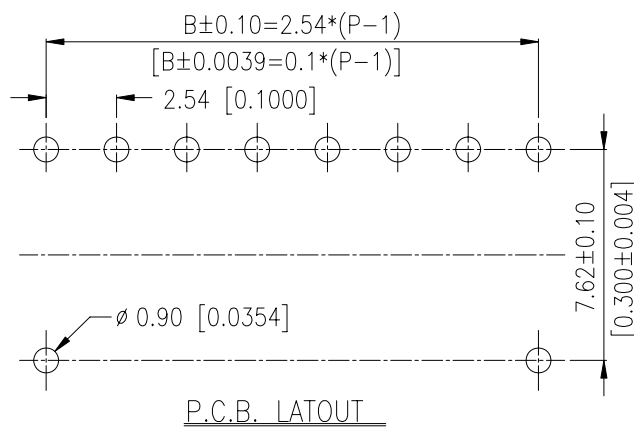
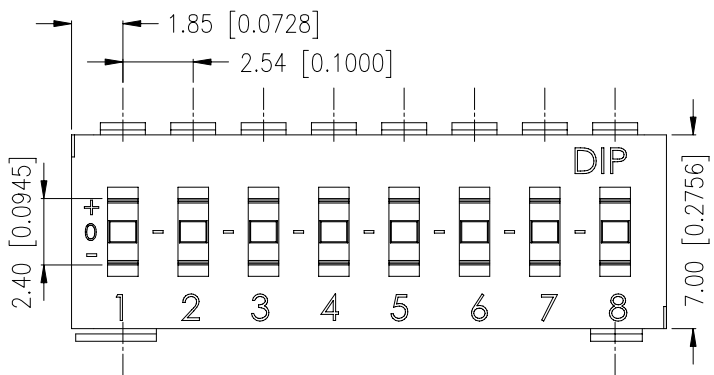

TII-10	10	26.56[1.046]	22.86[.900]
TIIR-10	10	26.56[1.046]	22.86[.900]
TII-09	9	24.02[.946]	20.32[.800]
TIIR-09	9	24.02[.946]	20.32[.800]
TII-08	8	21.48[.846]	17.78[.700]
TIIR-08	8	21.48[.846]	17.78[.700]
TII-04	4	11.32[.446]	7.62[.300]
TIIR-04	4	11.32[.446]	7.62[.300]
PROD. NO.	NO. OF POS.	DIM. A	DIM. B

General Tolerance : $\pm 0.2\text{mm}$

HOW TO ORDER

TI □ □ - □ □ - □ - V - □

Package Style

□ = Tube

T/R= Tape & Reel

Soldering :

V =Lead Free Solderable

Seal :

□ = Without Top Tape

T = Top Tape Sealed

(For recessed actuator only)

Number Of Positions :

04,08,09,10 Positions.

Actuator Type :

□ = Raised Actuator

R = Recessed Actuator

Terminal Type :

M = S.M.T Type

I = Through Hole Type

Tri-State IC Type

SPECIFICATION

△MECHANICAL

Mechanical Life: 2,000 operations.

Operation Force: 1,000gf max.

Stroke: 0.8 mm

Operation Temp: -20°C to +85°C

Storage Temperature: -40°C to +85°C

△ELECTRICAL

Electrical Life: 2,000 cycles.

Rating: 25 mA,24 VDC.

Contact resistance: 100mΩ max.

Dielectric Strength: 500VAC/1 minute.

Circuit: 3 switching positions.

SOLDERING PROCESSES

For best results, please follow these recommendation :

△ WAVE SOLDERING : Recommended solder temperature at 500°F(260°C) max. 5 seconds for through hole type.

△ HAND SOLDERING : Use a soldering iron of 30 watts, controlled at 350°C approximately max 5 seconds while applying.

△ REFLOW SOLDERING : When applying reflow soldering, the peak temperature or the reflow oven should be set at 260°C max.

△ Do not wash the switch body except top tape sealed type, which suitable for spray cleaning method from top of the s/w.

△ Any flux enters the switch may fail the conductivity.

△ Reflow Temperature Profile :

MATERIAL

△BASE & COVER: UL94V-0 Nylon High-Temp Thermoplastic. Color: Black.

△ACTUATOR: UL94V-0 LCP High-Temp Thermoplastic. Color: White.

△CONTACT: Alloy Copper with gold plated.

△TERMINAL: Brass with gold plated.

△TAPE: KAPTON.

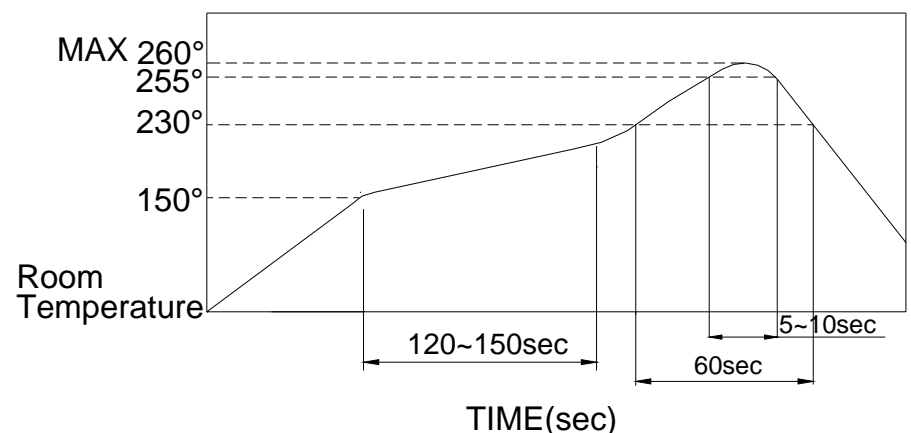

PACKING

PART NUMBER	Number Per Tube	Number Per Reel
TII(R)-04	41	-
TIM(R)-04		
TII(R)-08	22	-
TIM(R)-08		
TII(R)-09	20	-
TIM(R)-09		
TII(R)-10	18	-
TIM(R)-10		
TII(R)-04.08 09.10	-	900
TIM(R)-04.08 09.10		

TII(R) TUBE

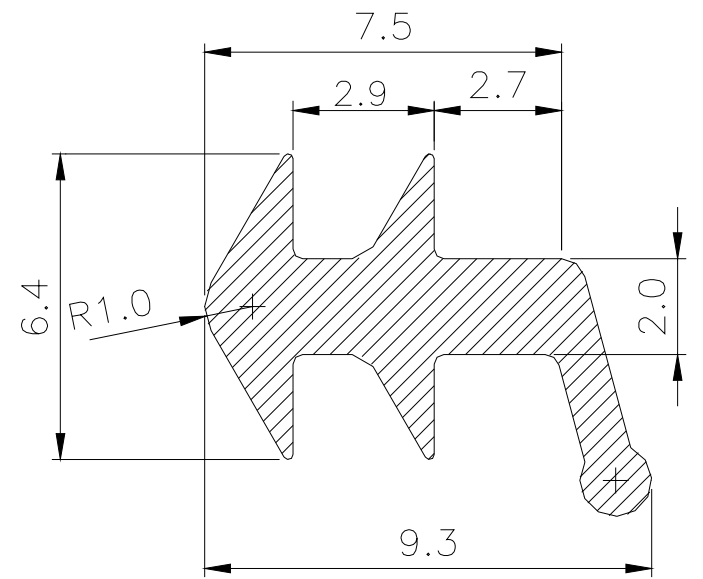
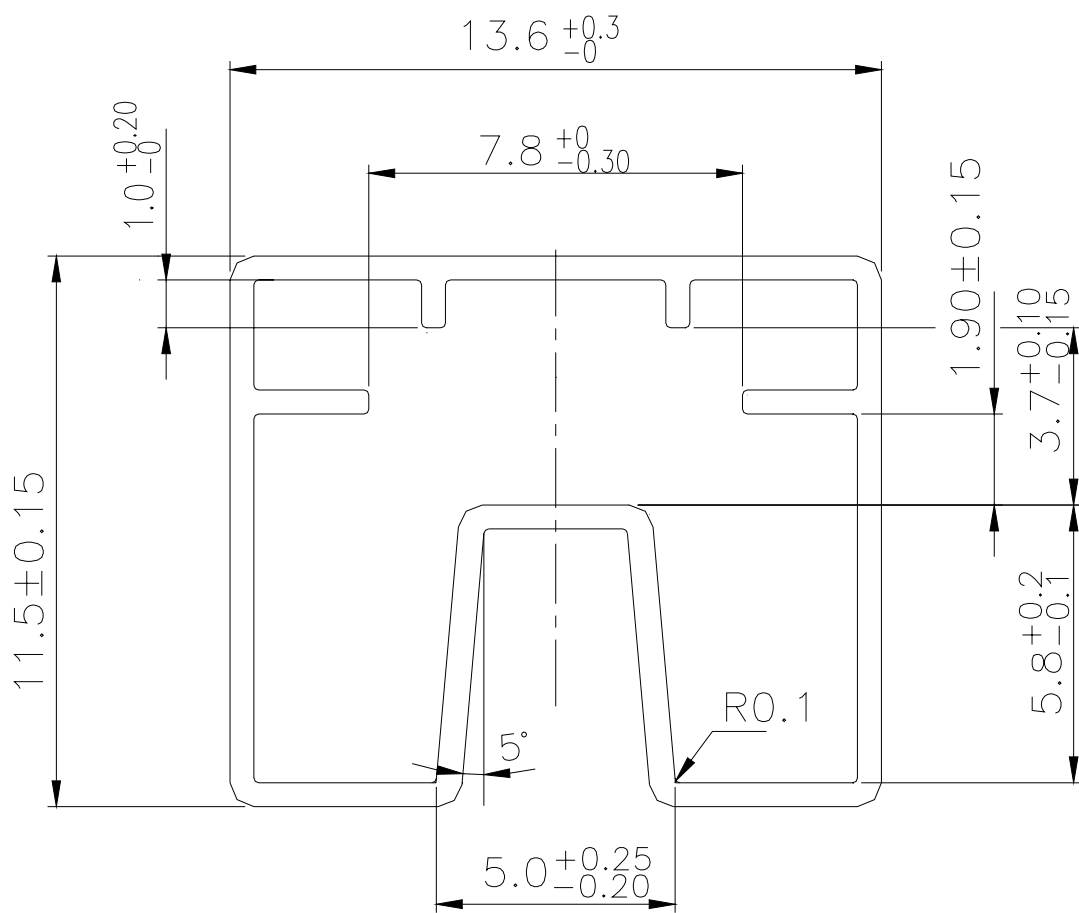

General Tolerance : ± 0.2 mm

TIM(R) TUBE

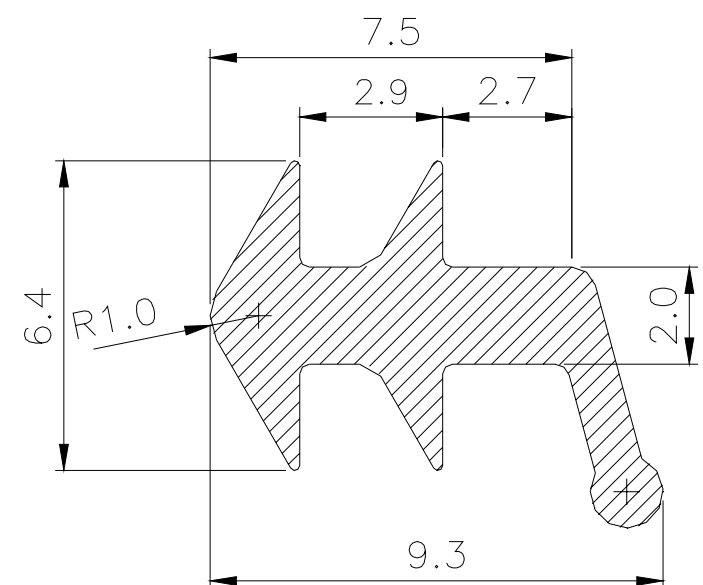
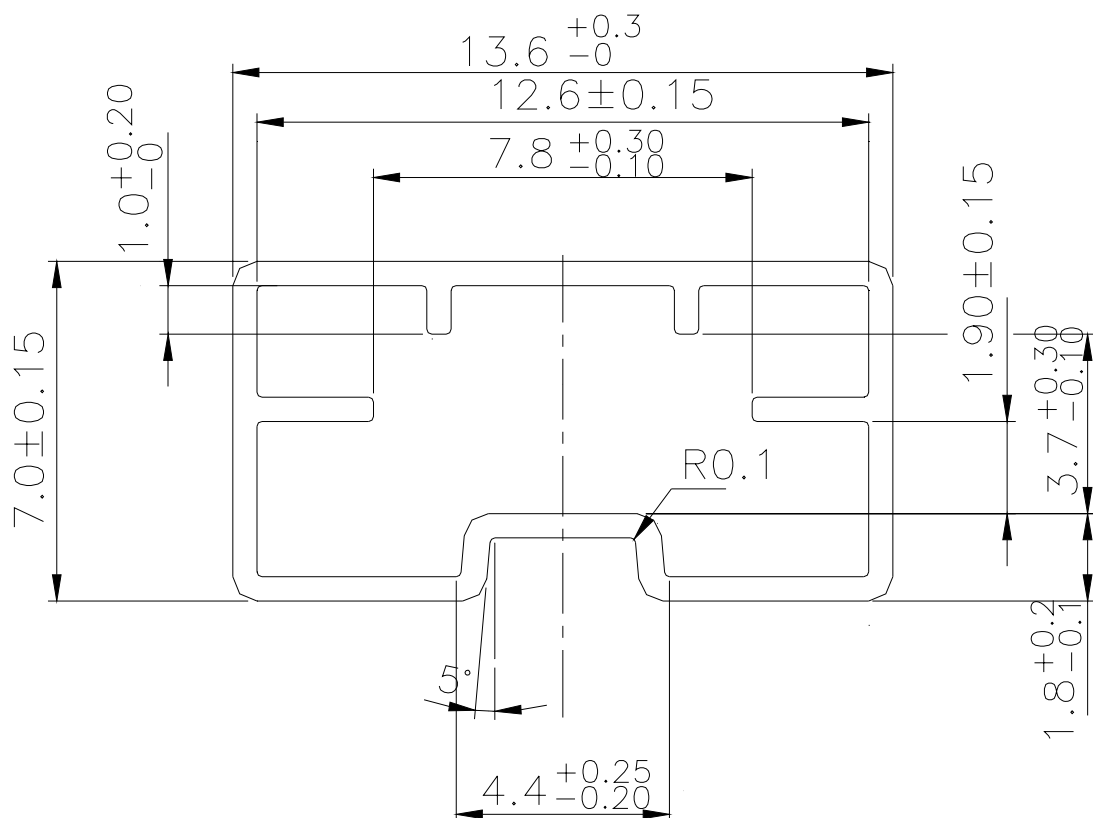

General Tolerance : ± 0.2 mm

TIM(R)-04 REEL

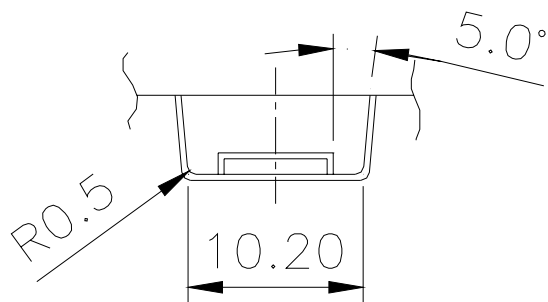
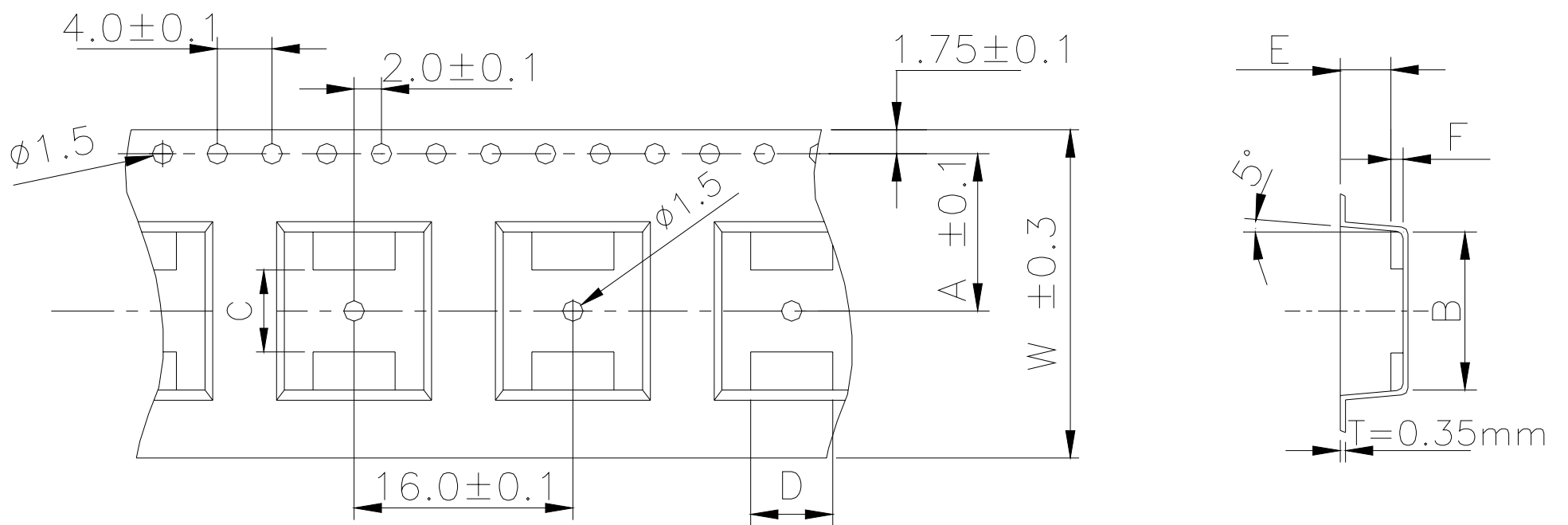

1. Pitch Tolerance Over Any 10 ± 0.20 .
2. Material: PS Black-Thickness : 0.35 ± 0.05 mm.
3. General Tolerances : ± 0.10 mm.

附註

TIM-04	620140000	24 ± 0.3	11.5 ± 0.1	11.56 ± 0.1	6 ± 0.1	6 ± 0.1	3.5	0.9
PART NAME	PART NO:	W ± 0.3	A	B	C	D	E	F

General Tolerance : ± 0.1 mm

TIM(R)-08.09.10 REEL

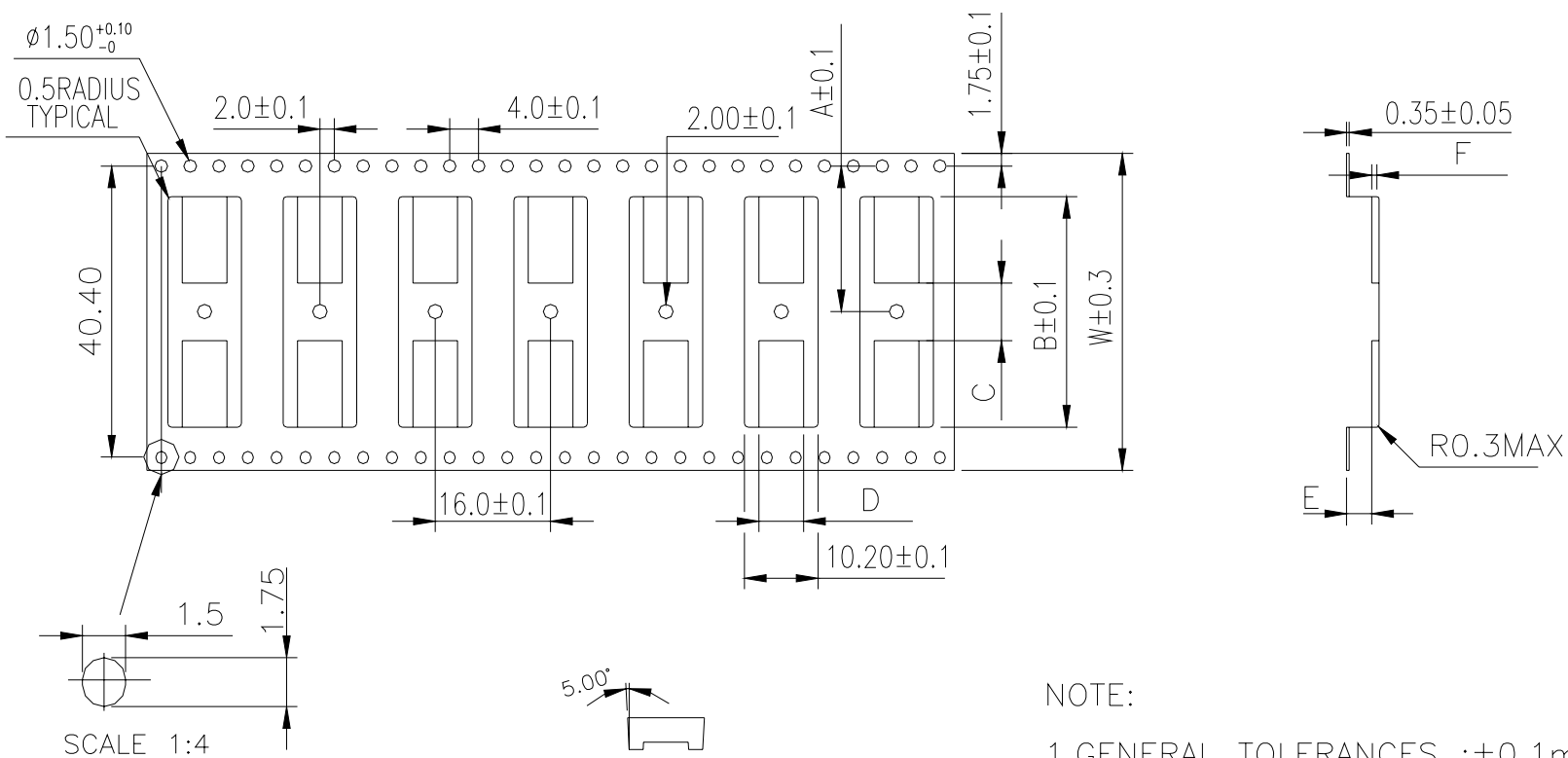

NOTE:

1. GENERAL TOLERANCES : ± 0.1 mm.

附註

TIM-10	6201A0000	44.00	20.20	26.80	5.0	6.00	4.5	0.4	40.40
TIM-09	620190000	44.00	20.20	24.26	5.00	6.00	4.5	0.4	40.40
TIM-08	620180000	32.00	14.20	21.70	6.00	6.00	3.5	0.9	28.40
PART NAME	PART NO.	W ± 0.3	A	B	C	D	E	F	G

General Tolerance : ± 0.1 mm